



Encoders



## ▶ Company Profile

Tianjin Geneuo Technology Co., Ltd. specializes in the development, production and sales of industrial automation products, system integration and engineering service.

- Communication solution

- Industry EtherNET Switch

- Fieldbus modules: ProfiNET, EtherNET/IP, EtherCAT, MODBUS TCP/IP I/O modules

- Inductive sensors

- Different housing design are available:M5 to M80 and cubic

- Optimized connection technology for efficient automation

- M5 to M40 receptacle, pre-moulding cable, field wireable connectivity

- Passive junction box and splitters

- Industrial network connectors for ProfiNET, EtherNET/IP, EtherCAT, MODBUS TCP/IP,Profibus,DeviceNET,CC-link.



- LED lighting

- Machine station lighting

- Factory lighting

- Intelligent lighting solutions



Geneuo exceptionally large product portfolio does not only cover all relevant standard solutions but also the special requirements of individual industries. The products and the total solution have been widely used in automotive, iron & steel, machine tool, elevator, textile, packaging, rubber machine etc.

## Economical- Incremental Encoders



Shaft version/shaft sleeve



Shaft version/shaft sleeve

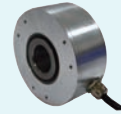

Shaft sleeve



Hollow taper / straight shaft

Series	HAE-38 Series	HAE-58 Series	HAE-90 Series	HAE-48 Series
Type	Incremental - Small	Incremental - General	Incremental - reload	Incremental - Servo
The main parameters				
Outside diameter	38mm	58mm	90mm	48mm
Shaft diameter	6mm	10mm	-	-
Axis aperture	6mm	8/10mm	25/30mm	6/8/9mm
Maximum rotational speed	6000 min <sup>-1</sup>	6000 min <sup>-1</sup>	6000 min <sup>-1</sup>	6000 min <sup>-1</sup>
The maximum radial shaft load	20 N	20 N	20 N	40 N
The maximum axle load axial	10 N	10 N	10 N	20 N
Operation temperature	-20 - 85°C	-20 - 85°C	-20 - 85°C	-20 - 85°C
Protection acc.to	IP54	IP54 or IP64	IP54	IP42
Connection	Cable outlet	Cable outlet	Cable outlet	Cable outlet
	-	-	-	-
Output form	TTL or push-pull	TTL or push-pull	TTL or push-pull	TTL
	-	-	-	-
Power supply	5V or 10-30V	5V or 10-30V	5V or 10-30V	5V or 10-30V
The maximum pulse frequency	Max125kHz	Max125kHz	Max100kHz	Max250kHz
Page number	Page 23	Page 25	Page 27	Page 29

Standard Type-  
Incremental Encoders

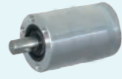

Shaft version



Shaft version/shaft sleeve



Shaft version



Shaft version/shaft sleeve

Series	HA-24 Series	HA-40 Series	HA-50 Series	HA-58 Series
Type	Incremental - miniature	Incremental - Small	Incremental - Compact	Incremental - General
The main parameters				
Outside diameter	24mm	40mm	50mm	58mm
Shaft diameter	6mm	6mm	8mm	6/8/10/12/mm
Axis aperture	-	6mm	-	8/10/12/14/15mm
Maximum rotational speed	12000 min <sup>-1</sup>	12000 min <sup>-1</sup>	12000 min <sup>-1</sup>	10000 min <sup>-1</sup>
The maximum radial shaft load	80 N	80 N	120 N	200 N
The maximum axle load axial	50 N	50 N	70 N	120 N
Operation temperature	-20 - 80°C	-30 - 80°C	-30 - 80°C	-20 - 80°C
Protection acc.to	IP65	IP65/IP67	IP65	IP65
Connection	Cable outlet	Cable outlet	Cable outlet	Cable outlet
	-	Outlet	Outlet	Outlet
Output form	TTL or push-pull	TTL or push-pull	TTL or push-pull	TTL or push-pull
	-	-	-	SinCos
Power supply	5V or 10-30V	5V or 10-30V	5V or 10-30V	5V or 10-30V
The maximum pulse frequency	Max200kHz	Max200kHz	Max200kHz	Max200kHz
Page number	Page 31	Page 33	Page 36	Page 38

Standard Type-  
Incremental Encoders



Shaft version/shaft sleeve



Shaft version



Shaft sleeve



Shaft sleeve

Series	HA-58H Series	HA-58AS Series	HA-80C Series	HA-A0 Series
Type	Incremental - High Temperature	Incremental - Stainless Steel	Incremental - big shaft sleeve	Incremental - Overloaded big shaft sleeve
The main parameters				
Outside diameter	58mm	58mm	80mm	100mm
Shaft diameter	6/8/10/12mm	10mm	-	-
Axis aperture	8/10/12/14/15mm	-	10/12/14/15/16/20/25mm	20/25/30/35/38/40/42/45
Maximum rotational speed	10000 min <sup>-1</sup>	6000 min <sup>-1</sup>	6000 min <sup>-1</sup>	3600 min <sup>-1</sup>
The maximum radial shaft load	200 N	100 N	200 N	200 N
The maximum axle load axial	120 N	100 N	100 N	100 N
Operation temperature	-20 - 100°C	-20 - 80°C	-40 - 80°C	-40 - 80°C
Protection acc.to	IP65	IP67	IP65	IP65
Connection	Cable outlet	Cable outlet	Cable outlet	Cable outlet
	Outlet	-	Outlet	Outlet
Output form	TTL or push-pull	TTL or push-pull	TTL or push-pull	TTL or push-pull
	SinCos	-	-	SinCos
Power supply	5V or 10-30V	5V or 10-30V	5V or 10-30V	5V or 10-30V
The maximum pulse frequency	Max 200kHz	Max 200kHz	Max 200kHz	Max 200kHz
Page number	Page 38	Page 43	Page 45	Page 47

Standard Type-  
Incremental Encoders

Shaft sleeve

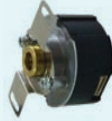

Hollow taper / straight shaft

Series	HA-145 Series	HA-48 Series
Type	Incremental - Overloaded big shaft sleeve	Incremental - Servo
The main parameters		
Outside diameter	145mm	48mm
Shaft diameter	-	-
Axis aperture	48/50/55/60/65/72mm	6/8/9mm
Maximum rotational speed	1600 min <sup>-1</sup>	6000 min <sup>-1</sup>
The maximum radial shaft load	200 N	40 N
The maximum axle load axial	100 N	20 N
Operation temperature	-40 - 80°C	-20 - 85°C
Protection acc.to	IP65	IP50
Connection	Cable outlet	Cable outlet
	Outlet	-
Output form	TTL or push-pull	TTL
	-	-
Power supply	5V or 10-30V	5V or 10-30V
The maximum pulse frequency	Max 200kHz	Max 500kHz
Page number	Page 49	Page 51

Absolute encoder  
- Lap



Shaft version/shaft sleeve    Shaft version/shaft sleeve    Shaft version/shaft sleeve    Shaft version/shaft sleeve

Series	HB2-58 Series	HB1-58 Series	HB4-58 Series	HB4-58 Series
Type	Absolute lap - Parallel	Absolute lap -SSI	Absolute lap -Profibus-Dp	Absolute lap -DeviceNet
The main parameters				
Outside diameter	58mm	58mm	58mm	58mm
Shaft diameter	6/10mm	6/10mm	6/10mm	6/10/12mm
Axis aperture	8/10/12mm	8/10/12/14/15mm	8/10/12/14/15mm	6/8/10/12/14/15mm
Maximum rotational speed	12000 min <sup>-1</sup>	12000 min <sup>-1</sup>	12000 min <sup>-1</sup>	12000 min <sup>-1</sup>
The maximum radial shaft load	110 N	110 N	110 N	110N
The maximum axle load axial	40 N	40N	40 N	40 N
Operation temperature	-40 - 85°C	-40 - 85°C	-40 - 85°C	-40 - 85°C
Protection acc.to	IP65/67	IP65/67	IP65/67	IP65/67
Connection	Cable outlet	Cable outlet	Cable outlet	Cable outlet
	Outlet	Outlet	Outlet	Outlet
Output form	Parallel port	SSI	Profibus-Dp	DeviceNet
Output code system	Binary/Gray/Gray-Excess	Binary/Gray	Binary	Binary
Power supply	10-30VDC	10-30VDC	10-30VDC	10-30VDC
The maximum single-turn resolution	16bits	16bits	16bits	16bits
The largest multi-turn resolution	-	-	-	-
Page number	Page 53	Page 57	Page 61	Page 65

Absolute encoder  
- Lap



Shaft version/shaft sleeve

Series	HB4-58 Series
Type	Absolute lap -CANopen/lift
The main parameters	
Outside diameter	58mm
Shaft diameter	6/10/12mm
Axis aperture	6/8/10/12/14/15mm
Maximum rotational speed	12000 min <sup>-1</sup>
The maximum radial shaft load	110 N
The maximum axle load axial	40 N
Operation temperature	-40 - 85°C
Protection acc.to	IP65/IP67
Connection	Cable outlet
	Outlet
Output form	CANopen/lift
Output code system	Binary code
Power supply	10-30VDC
The maximum single-turn resolution	16bits
The largest multi-turn resolution	-
Page number	Page 69



Absolute encoder  
- Multi-turn



Shaft version/shaft sleeve Shaft version/shaft sleeve Shaft version/shaft sleeve Shaft version/shaft sleeve

Series	HC1-58 Series	HC4-58 Series	HC4-58 Series	HC4-58 Series
Type	Absolute multiturn -SSI	Absolute multiturn - Profibus-DP	Absolute multiturn-DeviceNet	Absolute multiturn-CANopen /lift
The main parameters				
Outside diameter	58mm	58mm	58mm	58mm
Shaft diameter	6/10mm	6/10mm	6/10mm	6/10mm
Axis aperture	8/10/12mm	8/10/12/14/15mm	8/10/12/14/15mm	6/8/10/12/14/15mm
Maximum rotational speed	12000 min <sup>-1</sup>	12000 min <sup>-1</sup>	12000 min <sup>-1</sup>	12000 min <sup>-1</sup>
The maximum radial shaft load	110 N	110 N	110 N	110 N
The maximum axle load axial	40 N	40 N	40 N	40 N
Operation temperature	-40 - 85°C	-40 - 85°C	-40 - 85°C	-40 - 85°C
Protection acc.to	IP65/67	IP65/67	IP65/67	IP65/67
Connection	Cable outlet	Cable outlet	Cable outlet	Cable outlet
	Outlet	Outlet	Outlet	Outlet
Output form	SSI	Profibus-DP	DeviceNet	CANopen/lift
Output code system	Binary/Gray	Binary	Binary	Binary
Power supply	10-30V	10-30V	10-30V	10-30V
The maximum single-turn resolution	16bits	16bits	16bits	16bits
The largest multi-turn resolution	14bits	14bits	14bits	14bits
Page number	Page 73	Page 77	Page 81	Page 85

Practical application

Speed detection

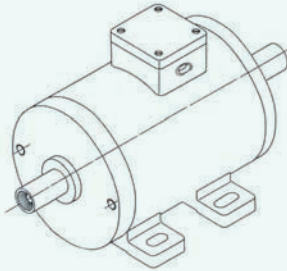

Angle detection

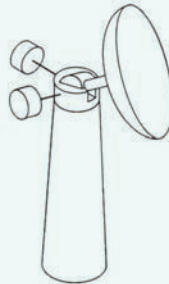

Position detection

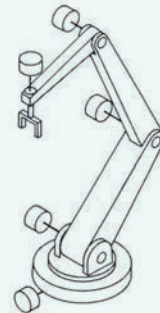

Multi-axis positioning

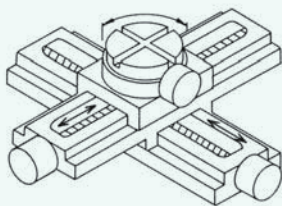

Length Detection

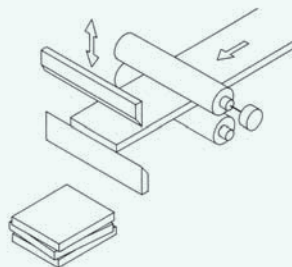

Fork bit detection

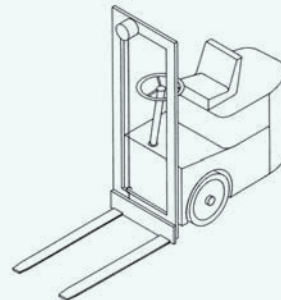

Crane location

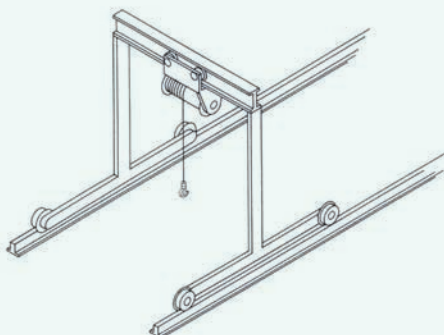

Position detection

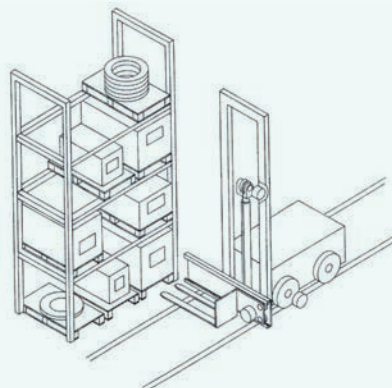

### Industry Applications

#### Drive Technology



Drive engineering field, we have many years of successful experience and numerous international partners. Outstanding product quality, highly flexible industrial applications, rapid globalization of services. For driving motors, torque motors, servo motor or other motor reliable, economical complete encoder solutions.

Main applications: motor speed detection, the motor speed feedback.

#### Iron and steel industry

Position and motion sensors in steel plays an important role. Even in very harsh environments, the encoder must also ensure safe and reliable, uninterrupted work. Safety and reliability are the main features of our products.

Main applications: iron, converter, continuous casting, hot rolling, cold rolling and other technology sectors can be used for speed control, position detection, linear measurements and angle measurements.



#### Wind power industry



In wind power, the harsh working environment encoder. The key factor is the long-term stability of the signal, our encoder can be used in high vibration or extreme temperatures.

Main applications: control and detection of rotor speed, rotor blade angle measurements, yaw angle measurement and control.

#### Machine tool industry

Requiring high precision machining digital measurement instruments and CNC tool to protect the processing accuracy, our encoder can provide accurate position feedback.

Main applications: motor speed, spindle positioning



### Automotive industry



Automobile manufacturing production process automation requirements of increasingly high, the need to accurately measure the encoder and precise positioning, we can provide the perfect solution.

Main applications: detection and measurement of mechanical rotation angle of the arm position.

### Elevator Industry

Elevator system must approximate the perfect fit for a variety of needs: reliability, high security, life and stability. Our encoder can perfect application in the industry.

Main application: for measuring the speed, and the synchronization and absolute position measurement.



### Construction Vehicles



Degree of automation and digitization project vehicles increasing, need precise positioning encoder.

Main applications: mechanical positioning, measurement, angle measurement locations.

### Logistics industry

Degree of automation of the logistics industry increasingly high, AGV car plays an important role in the auto logistics warehousing. Our encoder may provide accurate speed and position feedback.

Main applications: measuring the position feedback and truck speed

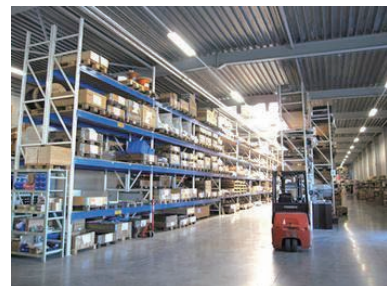

### Engineering and functional principle

The encoder (encoder) is the signal (such as bit stream), or data for the preparation, may be used to convert a signal in the form of communication, transmission and storage of the device. The angular displacement encoder or linear displacement into electrical signals, the former is called code disc, the latter known yardstick. According to the encoder readout mode can be divided into contact and non-contact two; in accordance with the principle can be divided into incremental encoders and absolute categories. Incremental encoder is to displacement into a periodic electrical signal, and then transform the electrical signal into a counting pulse, represents the magnitude of displacement by the number of pulses. Absolute encoders determine each position corresponds to a digital code, so it only shows the value of the starting and ending position measurement, but not to the middle of the process of measurement.

In the field of automation, is a rotary encoder for monitoring or feedback rotation angle of movement, position, velocity or acceleration of digital sensors, relying on screw, gear, measuring wheel or the auxiliary cable is also used for wire-line displacement detector positioning. It will be converted to mechanical rotation parameters corresponding electrical signals sent to the counter, tachometer, PLC or industrial PC or other host device for processing, the final completion of the closed-loop feedback control.

### Encoder by Category

#### Engraved plate hole by way of different classification codes

Incremental: that angle per unit turned on the issue of a pulse signal (also made positive cosine signal, which is then broken down, chopping out the higher frequency pulse), usually for the A phase, B phase, Z phase output, A-phase, B-phase pulse output is delayed by 1/4 cycle to each other, the relationship can be differentiated according to the delay inversion, and by taking the a phase, B phase of rising and falling edges can be 2 or 4-fold; Z-phase single turn pulses per revolution that sends a pulse.

Absolute: is the corresponding circle, each benchmark issue a unique angle corresponding to the angle of the binary values, lap record by an external device can record multiple locations and measurements.

According to the type of output signal is divided into:

Voltage output, open collector output, complementary push-pull outputs and long-term drive output.

The encoder mechanical mounting into the form:

Shaft Type: shaft type can be divided into clamping flange, servo flange type and servo mount type.

Sleeve type: sleeve type can be divided into the air, fully air-type and large-caliber type.

The encoder works can be divided into:

Photoelectric, magnetic and electric brush type contacts.

## Environmental Requirements

When using the encoder, the encoder environment is a significant effect on the life of factors, such as:

Ambient temperature  
Axle load requirements  
Dust, liquids, temperature rating

Because of the design and use of high quality components, our encoder for harsh conditions.

## Temperature

According to DIN32 878 standard

Working temperature

Temperature

Where the encoder signal to produce normal ambient temperatures, the values refer to the parameter list.

The encoder will not be able to withstand the change in the ambient temperature.

## Dust / water resistance

According to EN 60529 describes the IP rating to indicate the encoder dust and water resistance. After referred to as IP and connect two digits are explained below.

The first digit is defined as the size of the dust particles.

The higher the number the smaller the particles, said.

The second digit is defined as water resistance. The higher the value, the greater the anti-water pressure.

Our encoder protection class up to IP 67

The following overview IP rating

### Anti-dust particle protection (first digit)

- 0 No protection
- 1 Dust particles  $\geq 50\text{mm}$
- 2 Dust particles  $\geq 12,5\text{mm}$
- 3 Dust particles  $\geq 2,5\text{mm}$
- 4 Dust particles  $\geq 1,0\text{mm}$
- 5 Dust protection
- 6 Dust Certification

### Waterproof protection (second digit)

- 0 No protection
- 1 Vertical drip protection
- 2 Partial protection against dripping vertical of  $15^\circ$
- 3 For partial vertical  $60^\circ$  splash water protection
- 4 Directly immersed in the whole direction of the splash water protection against water
- 5 Directly immersed in the whole direction of the low-pressure spray of water protection against water
- 6 High-pressure direct injection water immersion protection, for example, on the deck of the ship, to prevent water
- 7 Protection against water immersion between 15 cm to 1 m of
- 8 When the pressure on long-term water immersion protection

## Color short Standards based DN757

Shorthand	Color	Shorthand	Color
BK	Black	VT	Violet
BN	Brown	GY	Gray
RD	Red	WH	White
OG	Orange	PK	Pink
YE	Yellow	GD	Gold
GN	Green	TQ	Turquoise
BU	Blue	SR	Silver



## Number of channels

### Single-channel output encoder :

Application examples for single channel encoder output is not required to detect the direction of: speed control or length detection.

### Dual output encoder :

Applied to detection of the direction of rotation, for example: location, with the phase difference required for the two encoder channels A and B 90°, the phase difference is detected, may determine its orientation.

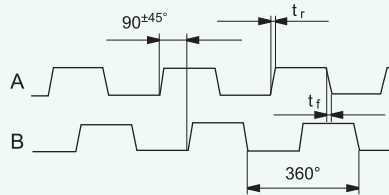

- From the top of the rotary shaft encoder, the rotary shaft clockwise
- Provide inverted signals

$t_r$  = Rise Time

$t_f$  = Fall Time

### Three-channel output encoder

Additionally provided a zero signal on the basis of dual channel A and B, the once per revolution. Available after power reference signal during the first turn.

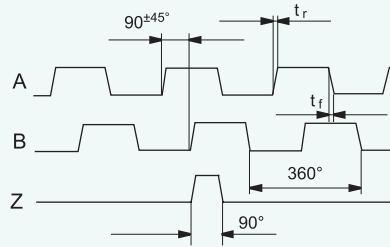

From the top of the rotary shaft encoder, the rotary shaft clockwise

- Provide inverted signals
- 0-Pulses A and B "and"

$t_r$  = Rise Time

$t_f$  = Fall Time

## Pulse multiplier

Dual-channel encoder is implemented by detecting double pulse resolution along the edge or four octave.

A 5000ppr resolution encoder uses the technique available 20000ppr resolution.

## Inverted signals

When used in electrical noise interference is serious and may need long cable runs, we recommend using an encoder with inverted signals.

These signals can be provided to the RS 422 output and sine output type push-pull output line for the signal type is also available.

## Resolution

For example: with a measuring wheel encoder. Each turn corresponds to 200 mm (circumference). Accuracy of 0,1 mm. Desired resolution (ppr) should be how much?

Is given by: circumference measuring wheel: C = 200 [mm]

System accuracy: G = 0,1 [mm]

Expectations: encoder resolution: A = ? [pulses / rev]

$$\text{Resolution} = \frac{\text{Perimeter}}{\text{Accuracy}} = \frac{U}{G}$$

Desired resolution for 2000ppr (number of pulses per revolution).

## Pulse frequency

Desired pulse frequency by the number of pulses per revolution (ppr) and speed (rpm) values calculated. The maximum pulse frequency of each encoder are listed in the technical parameters. Typically 300kHz. Also provides a pulse frequency of up to 800kHz high-resolution encoder.

For example:

Example calculation of the required pulse frequency  $f_{max}$  :

Given : Speed  $n=3000 \text{ min}^{-1}$

Encoder resolution  $R=1000\text{ppr}$

$$f_{max} = \frac{n \times A}{60}$$

Desired pulse frequency is 50kHz. Now you can compare the results with respect to your expectations choice encoder parameters.

The following figure is available as a quick check pulse frequency

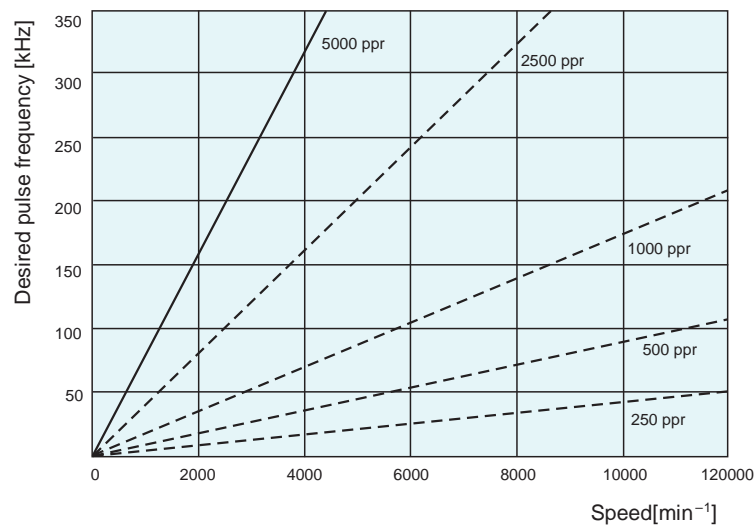

## Output and power supply voltage (Review)

For a variety of applications possible output and supply voltage.

Export	Inverted signals	Supply voltage
RS 422	Have	5 V DC
RS 422	Have	10 ... 30 V DC or 5 ... 30 V DC
Push-pull output	No	10 ... 30 V DC or 5 ... 30 V DC
Push-pull output	Have	10 ... 30 V DC or 5 ... 30 V DC
Push(7272)	Have	5 ... 30 V DC
Sinusoidal voltage output	Have	5 V DC

The encoder is used to strong electrical noise interference and required a longer cable, we recommend using an inverted signal.

## Sensor output

As the distance from the encoder to the control unit when the encoder side is very long supply voltage will decay, using the sensor output in this case.

Since the sensor input (controller terminal) of the input impedance is very high, so the voltage drop at the sensor output is almost zero.



## Digital Output

Sinusoidal signal generated by the optical system first digitized into a square wave signal.

- From the top of the encoder shaft, the rotating shaft in a clockwise
- Provide inverted signals
- Z pulse for channels A and B and

Transmission signal can be output in two ways. RS 422 (TTL compatible) or push (containing PNP or NPN)  
On the choice of the specific application with the appropriate output should consider the following:

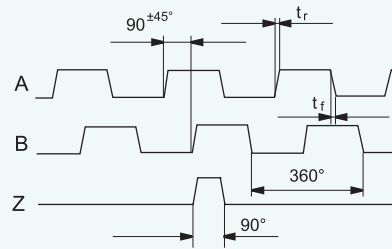

- And the corresponding unit connected encoder or controller
- From the encoder to the receiving unit of the distance
- Sensitivity to electrical noise or other interference

## Input line RS 422 output lines and requirements

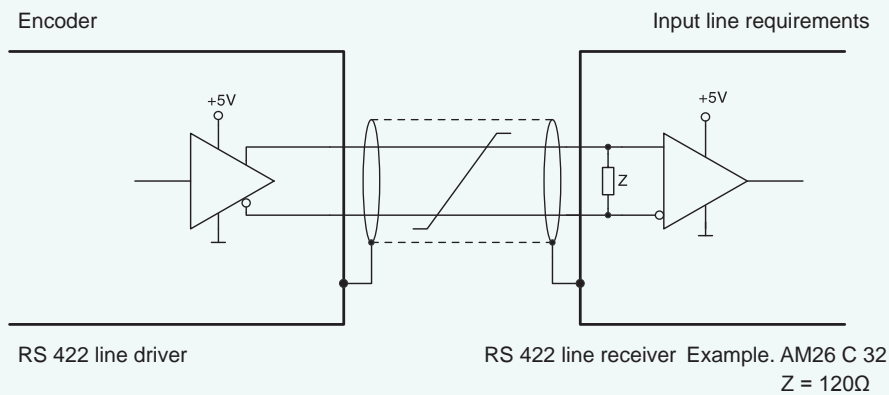

## Push-pull output

With push-pull output matching counter, interface cards or PLC output interface has the following two versions

Push-pull output :

- A complete wave resistance adjustment is recommended for cable resistance 40-150Ω
- Recommended for long cable runs, high pulse frequency and 30V output voltage
- With or without inverted signals

Push-pull output ( 7272 ) :

- General line drive 5-30V, Have low limit (maximum of 0.5V)
- Recommended cable lengths up to 30 m
- With inverted signals

## Have inverted signal output line and claimed

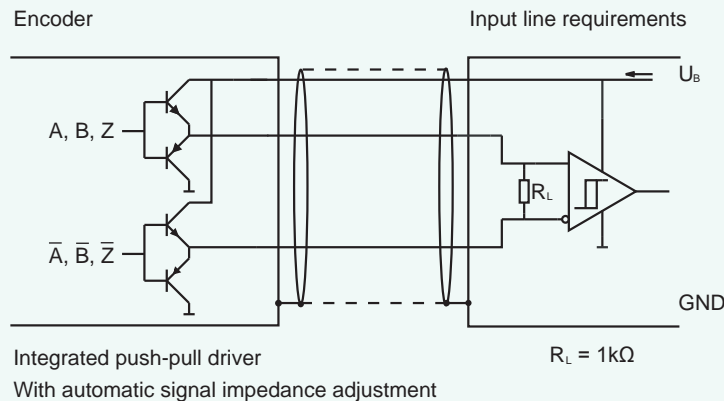

No push-pull output and the inverting input signal circuit

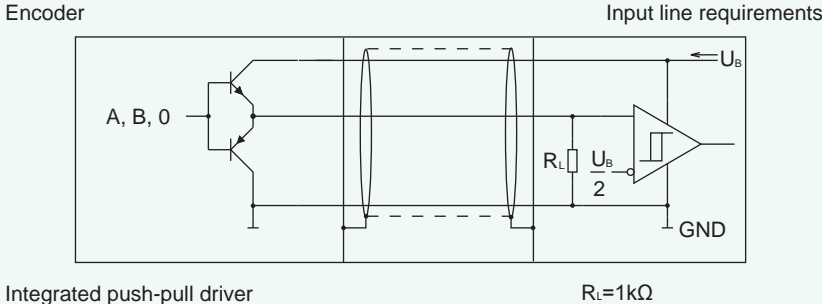

Sine wave output

Sine wave is a sine wave voltage signal provided. Sinusoidal signal can usually be multiplier, multiplier multiples: 10, 20, 100, 400,500,1000, etc., binary multiples such as: 512, 1024 and so on. Because the output signal of the differential output is positive cosine, the phase difference is 90°, so it was still a very high resolution of frequency doubling.

This makes this particular signal can be used in high resolution requirements of the occasion. This signal can then digital drive with good precision displacement control minor, such as: close grinders, lifts, elevators, etc.

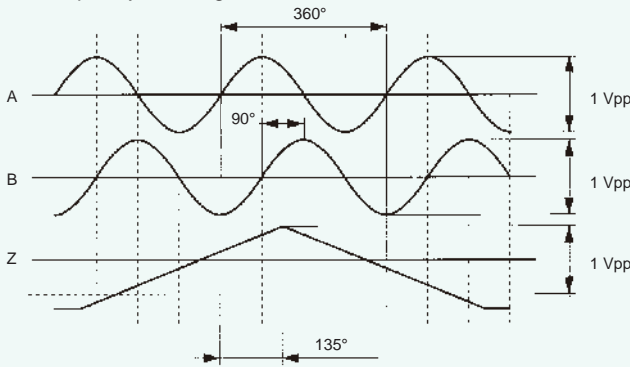

- The axis of rotation : Observed for clockwise shaft surface wave
- Z- pulse appears only once per lap

Sine wave output voltage signal input circuit lines and requirements

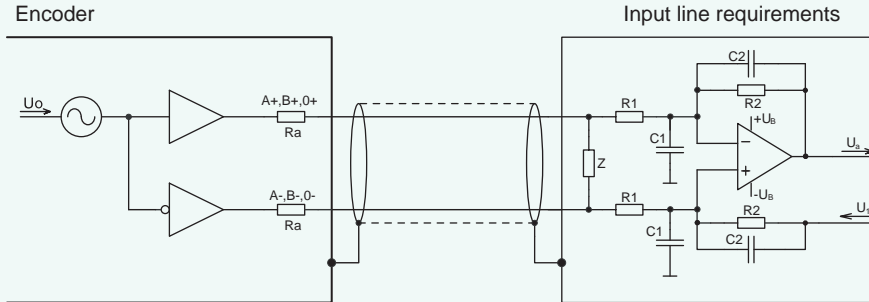

- $R_a = 10\Omega$
- $C_1 = 150\text{ pF}$
- $C_2 = 10\text{ pF}$
- $R_1 = 10\text{ k}\Omega$
- $R_2 = 33\text{ k}\Omega$
- $U_0 = 2.5\text{ V} \pm 0.5\text{ V}$
- $Z = 120\Omega$
- $U_1 = U_0$

## Parts and functions

The encoder uses photoelectric scanning principle. And with a radial gap of the wire grid code wheel, between the light source (typically a LED) and a rotating receiver, generates a signal proportional to the received light.

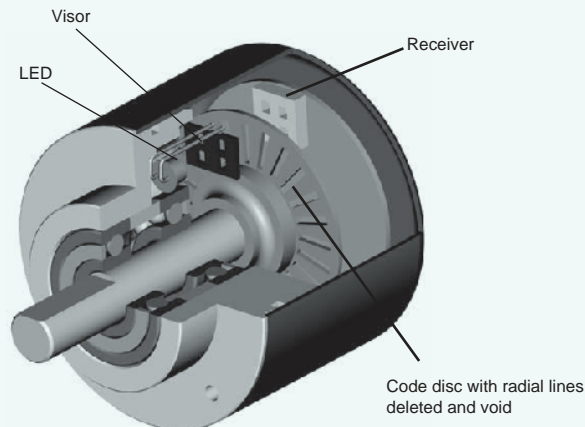

## Cable length :

Cable length depends on the circumstances provided in the following output lines and electrical noise interference :

Output lines	Maximum cable length	The encoder is connected to
No inverted push-pull output signal	100m	Counter / PLC
Push-pull output with inverted signals	250m	PLC/PC
Push-pull output with inverted signals ( 7272 )	30m	PLC/PC
RS 422 with inverted signals	Up to 1000 m (> 50m depending on the frequency of the time)	PLC/PC
Sinusoidal voltage with inverted signals	50m	PLC/PC

## Absolute encoders

### Design and Function

For an absolute encoder LED beam is interrupted rotation encoder dark areas. Then on the code disk with concentric tracks on a numeric code to replace dash, read by a dedicated chip. A unique bit pattern to determine the value of each digit position.

Advantages: determining the real position obtained after a power failure on the power again, especially during the power-down movement can also be achieved if the axis is detected actual position.

With incremental encoder is different after starting without reference drivers. Improve safety while saving reference drivers between.

### Encoding type

Binary code:

Binary computer system can be quickly addressed. When using the optical system to read, easy to produce code is wrong, because the code in different concentric tracks (LSB, LSB + 1 ...) from a

Another change to the precise synchronization is not guaranteed, but there are a number of digital change. Thus, without any encoding validation, the position error information can be generated.

Bit 1 (LSB)																
Bit 2																
Bit 3																
Bit 4 (MSB)																
Significance	0	1	2	3	4	5	6	7	8	9	10	11	12	13	14	15

### Gray code

Gray code is a single shot yards. This means the only one to change from one position to the next position. Improve the reliability of the detected coding, will improve the reliability of position detection.

Gray code for all absolute optical encoder readout.

### I Gray code

Extracted partially qualified Gray Gray code I produce yards.

This code allows a group.of even-resolution, Example : 360, 720, 1000

Bit 1 (LSB)																
Bit 2																
Bit 3																
Bit 4 (MSB)																
Corresponding values	0	1	2	3	4	5	6	7	8	9	10	11	12	13	14	15

Bit 1 (LSB)										
Bit 2										
Bit 3										
Bit 4 (MSB)										
Corresponding values	0	1	2	3	4	5	6	7	8	9

**Output :** For transmitting position data to the controller, can provide several interface types.

**Parallel Output :** This type of transmission is very fast. Corresponds to a position of full digital bit corresponding transmission simultaneously by different routes.

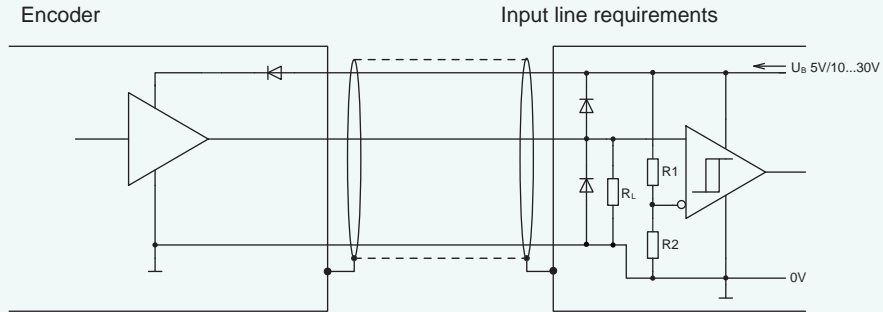

**SSI Synchronous Serial Interface :**

Integrated push-pull driver

Compared with a parallel interface, SSI interface required fewer components, and EMC- characteristics better. Another transmission cable diameter is smaller, the cable length can be increased.

SSI output interface circuits and require the input line :

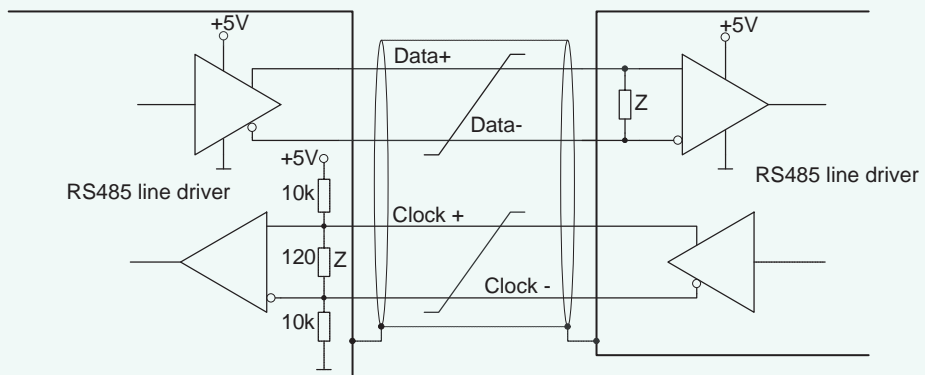

**Data transfer :**

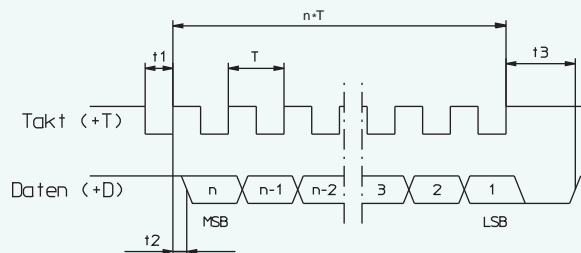

- $t_1 = T/2$
- $t_2 < T/4$  (4 x fmax Maximum frequency)
- $t_3 =$  Monostable time (see below)
- $1 / f_{max} \leq T \leq 1 / f_{min}$
- $f_{max} =$  SSI maximum clock frequency
- $f_{min} =$  SSI minimum clock frequency
- $n =$  Resolution (Bits)

Static, the clock and data lines are high. The first pulse falling initiate the data transfer. Bit data transfer from the rising edge after the first falling edge of a pulse start transmission MSB --- most significant bit. A complete data transmission line needs pulse rising edge of  $n + 1$  ( $n =$  resolution --- digits), such as:

13 resolution encoder requires 14 clock pulses. After the final positive clock signal, the data line is held low until the encoder is ready to begin transmission of a new row of data. The clock line and the data line must be maintained for at least as long as the high level, and after the first falling edge to the falling edge of pulse sequence starts reading data.

## Installing the Sample

## Clamping flange mounting screws

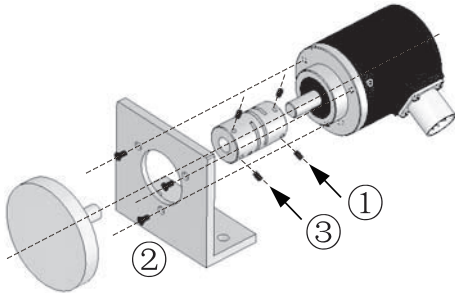

- 1, the coupling attached to the encoder
- 2, the encoder mounted to the bracket
- 3, the suit and the measured shaft couplings

## Synchronous eccentric mounting flange

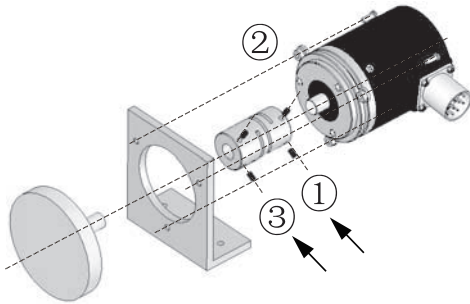

- 1, the coupling attached to the encoder
- 2, the encoder mounted reached by the eccentric bracket
- 3, the suit and the measured shaft couplings

## Square flange mounting

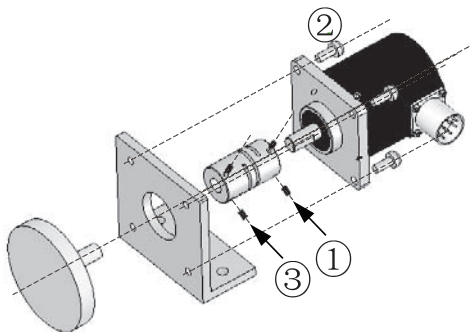

- 1, the coupling attached to the encoder
- 2, the encoder mounted reached by the eccentric bracket
- 3, the suit and the measured shaft couplings

## Installing the Sample

Short stop pin installation diagram

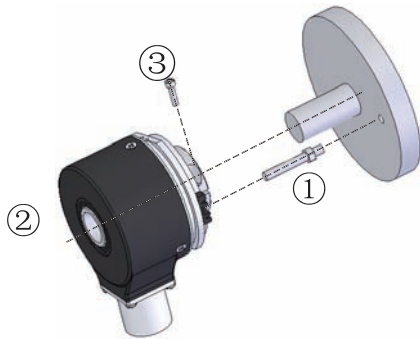

- 1, the short stop pin means mounted to the motor frame or
- 2, the encoder is passed through a short stop pin bushing in the measured shaft, the rear end surface and to ensure that the stop pins have a supporting bottom margin of 0.8mm
- 3, fastening screw lock ring encoders

Spring piece installation diagram

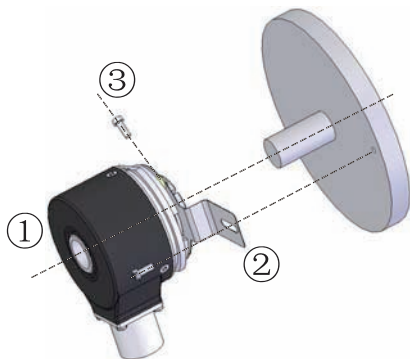

- 1, the encoder sets the motor
- 2, the fixed spring leaves
- 3, fastening screw lock ring encoders

Long ledges installation diagram

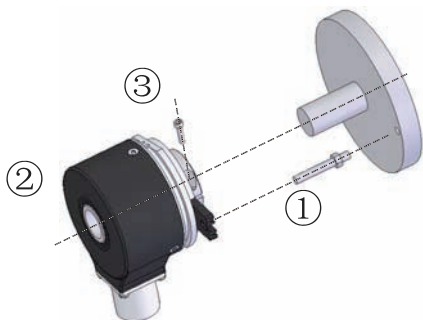

- 1, the length of the stop pin means mounted to the motor frame or
- 2, the encoder is passed through a short stop pin bushing in the measured shaft, the rear end surface and to ensure that the stop pins have a supporting bottom margin of 0.8mm
- 3, fastening screw lock ring encoders

Wings shrapnel installation diagram

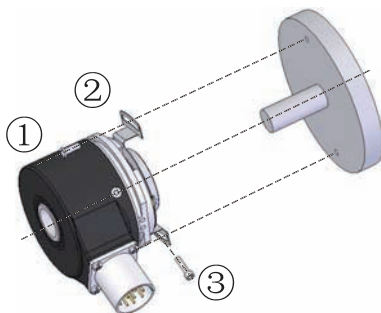

- 1, the encoder sets the motor
- 2, the fixed spring leaves
- 3, fastening screw lock ring encoders

Economical HAE-38



- Dimensions only 38mm, With high cost performance
- Small size, easy installation
- Can effectively reduce the installation space, cost savings
- Protection class IP54/IP65
- Operating temperature range (-20 - 85 ° C)



**Mechanical characteristics**

Max.speed	6000 min <sup>-1</sup>
Starting torque	0.03 N.m MAX
Moment of inertia	≤ 20 gcm <sup>2</sup>
Shaft load capacity -radial	20 N
Shaft load capacity -axial	10 N
Protection EN 60 529	IP54/IP65
Operation temperature	-20 - 85°C
Materials	Shaft:Stainless steel
Weight	About 0.100 kg
Shock resistanceEN 60068-2-29	1000m/s <sup>2</sup> , 6ms
Vibration resistance EN 60068-2-27	100m/s <sup>2</sup> , 10-2000Hz

**Electrical characteristics**

Output circuit	Driver ( TTL )	Push-Pull
Power supply	5VDC	10-30VDC
Power consumption	Max. 150mA	Max. 150mA
Permissible load/channal	Max. 30mA	Max. 30mA
Pulse frequency	Max. 125kHz	Max. 125kHz
Signal level- High	Min. 2.5V	Min. Ub-2.5V
signal level- Low	Max. 0.5V	Max. 0.5V
Rising edge time t <sub>r</sub>	Max. 100 ns	Max. 100 ns
Falling edge time t <sub>f</sub>	Max. 100 ns	Max. 100 ns
Power protection	No	YES
UL-approval	File	
CE requirement acc.to	EN 61000-6-2:2006 ; EN 6100-6-3:2007	

Terminanl assignment:

Signal	Ub	GND	A	$\bar{A}$	B	$\bar{B}$	Z	$\bar{Z}$	Shield
Cable color	BN	WH	GN	YE	GY	PK	BU	RD	



## Shaft version-dimension

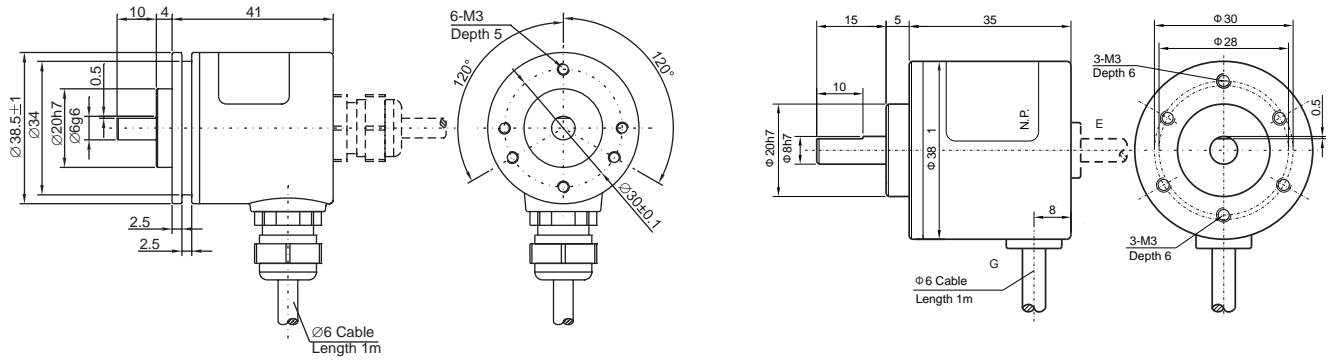

## Hollow shaft-dimension

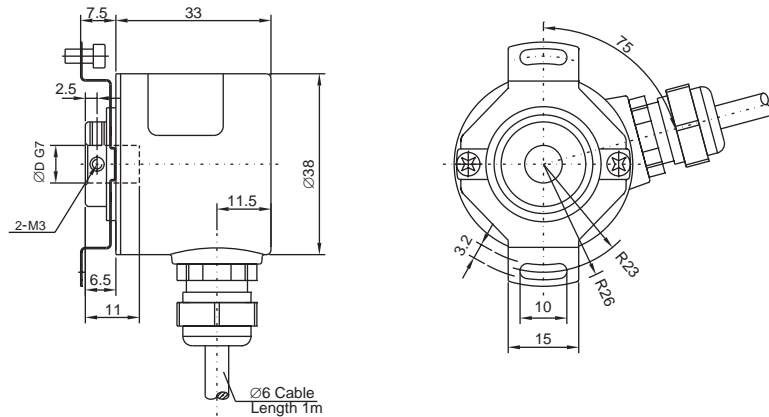

### Order code- shaft version

HAE-38A-XXXX-XXXX  
 Series - economical    A    B C D E

**A resolution**  
 500,1000,1024

**C Shaft diameter**  
 2=  $\varnothing$  6x10mm  
 3=  $\varnothing$  6x15mm  
 4=  $\varnothing$  8x15mm

**D Output circuit /Power supply**  
 1= TTL Line Driver / supply voltage 5VDC  
 3= Push-Pull ( without inverted signal ) / Power supply 10~30VDC  
 5= Push-Pull ( with inverted signal ) / Power supply 10~30VDC

**B Flange Type**  
 1 = Clamping flange

**E Type of connection**  
 2 = Radial cable

### Order code- Hollow shaft

HAE-38C-XXXX-XXXX  
 Series - economical    A    B C D E

**A resolution**  
 500,1000,1024

**C Shaft diameter**  
 3 =  $\varnothing$  6mm  
 4 =  $\varnothing$  8mm

**E Type of connection**  
 2 = Radial cable

**B Flange Type**  
 1 = Blind hollow shaft

**D Output circuit /Power supply**  
 1 = TTL Line Driver / supply voltage 5VDC  
 3 = Push-Pull ( without inverted signal ) / Power supply 10~30VDC  
 5 = Push-Pull ( with inverted signal ) / Power supply 10~30VDC

Economical HAE-58



- Dimensions 58mm, perfect used in various automation industry
- Polymer grating, good shock resistance
- A variety of mounting options, easy to use
- High degree of protection IP54/IP65, good environmental resistance
- Operating temperature range (-20 - 85 ° C)



**Mechanical characteristics**

Max.speed	6000 min <sup>-1</sup>
Starting torque	0.03 N.m MAX
Moment of inertia	≤ 20 gcm <sup>2</sup>
Shaft load capacity -radial	20 N
Shaft load capacity -axial	10 N
Protection EN 60 529	IP54/IP65
Operation temperature	-20 - 85°C
Materials	Shaft : Stainless steel
Weight	About 0.270 kg
Shock resistance EN 60068-2-29	1000m/s <sup>2</sup> , 6ms
Vibration resistance EN 60068-2-27	100m/s <sup>2</sup> , 10-2000Hz

**Electrical characteristics**

Output circuit	Driver ( TTL )	Push-Pull
Power supply	5VDC	10-30VDC
Power consumption	Max. 150mA	Max. 150mA
Permissible load/channal	Max. 30mA	Max. 30mA
Pulse frequency	Max. 125kHz	Max. 125kHz
signal level- High	Min. 2.5V	Min. Ub-2.5V
signal level- Low	Max. 0.5V	Max. 0.5V
Rising edge time t <sub>r</sub>	Max. 100 ns	Max. 100 ns
Falling edge time t <sub>f</sub>	Max. 100 ns	Max. 100 ns
Power protection	No	YES
UL-approval	File	
CE requirement acc.to	EN 61000-6-2:2006 ; EN 61000-6-3:2007	

Terminal assignment:

Signal	Ub	GND	A	$\bar{A}$	B	$\bar{B}$	Z	$\bar{Z}$	Shield
Cable color	BN	WH	GN	YE	GY	PK	BU	RD	

## Shaft version-dimension

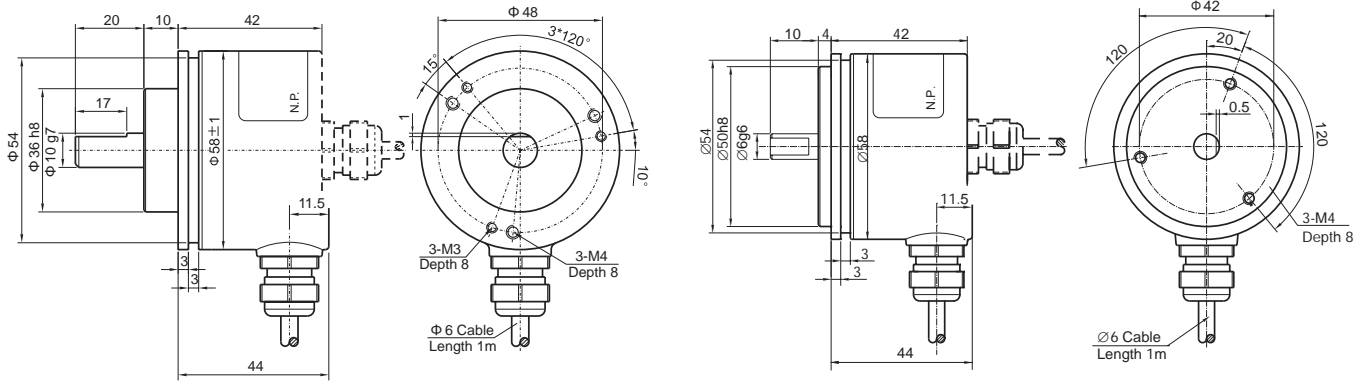

## Hollow shaft-dimension

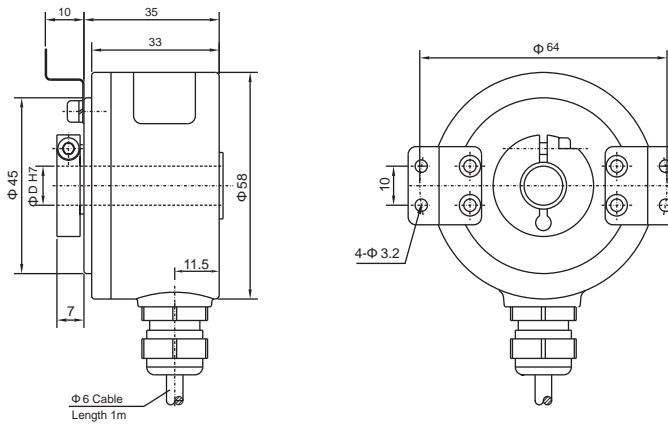

### Order code- shaft version

HAE-5 8 A - X X X X - X X X X

Series - economical    A    B C D E

**A resolution**  
500,1000,1024

**C Shaft diameter**  
2 =  $\varnothing$  6 x 10 mm  
5 =  $\varnothing$  10 x 20 mm

**E Connection**  
2 = Radial cable

**B Flange Type**  
1 = Clamping flange  
3 = Synchro flange

**D Output/Power supply**  
1 = TTL Line Driver / Power supply 5VDC  
3 = Push-Pull ( without inverted signal ) / Power supply 10~30VDC  
5 = Push-Pull ( with inverted signal ) / Power supply 10~30VDC

### Order code- Hollow shaft

HAE-5 8 C - X X X X - X X X X

Series - economical    A    B C D E

**A resolution**  
500,1000,1024

**C Shaft diameter**  
4 =  $\varnothing$  8 mm  
5 =  $\varnothing$  10 mm  
6 =  $\varnothing$  12 mm

**E Connection**  
2 = Radial cable

**B Flange Type**  
8 = Flying wing through hollow shaft (The lock ring on the flange side)

**D Output/Power supply**  
1 = TTL Line Driver / Power supply 5VDC  
3 = Push-Pull ( without inverted signal ) / Power supply 10~30VDC  
5 = Push-Pull ( with inverted signal ) / Power supply 10~30VDC

Economical HAE-90

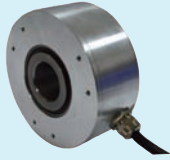

- heavy-duty, maximum aperture of 30mm
- The number of pulses up to 5000PPR
- Polymer grating, super good shock resistance
- High degree of protection, resistance to harsh environments
- Perfect applied to various ports, metallurgy, mining machinery and automation industry



**Mechanical characteristics**

Max.speed	6000 min <sup>-1</sup>
Starting torque	0.05 N.m MAX
Moment of inertia	≤ 20 gcm <sup>2</sup>
Shaft load capacity -radial	20 N
Shaft load capacity -axial	10 N
Protection EN 60 529	IP54
Operation temperature	-20 - 85°C
Materials	Shaft : Stainless steel ; flange、Housing material : aluminium alloy
Weight	About 0.850 kg
Shock resistance EN 60068-2-29	1000m/s <sup>2</sup> , 6ms
Vibration resistance EN 60068-2-27	100m/s <sup>2</sup> , 10-2000Hz

**Electrical characteristics**

Output circuit	Driver ( TTL )	Push-Pull
Power supply	5VDC	10-30VDC
power consumption	Max. 150mA	Max. 150mA
Permissible load/channal	Max. 30mA	Max. 30mA
Pulse frequency	Max. 100kHz	Max. 100kHz
Signal level- High	Min. 2.5V	Min. Ub-2.5V
Signal level- Low	Max. 0.5V	Max. 0.5V
Rising edge time t	Max. 100 ns	Max. 100 ns
Falling edge timet	Max. 100 ns	Max. 100 ns
Power protection	No	With
UL-approval	File	
CE requirement acc.to	EN 61000-6-2:2006 ; EN 6100-6-3:2007	

Terminanl assignment:

Signal	Ub	GND	A	$\bar{A}$	B	$\bar{B}$	Z	$\bar{Z}$	Shield
Cable(color mark)	BN	WH	GN	YE	GY	PK	BU	RD	

## Hollow shaft-dimension

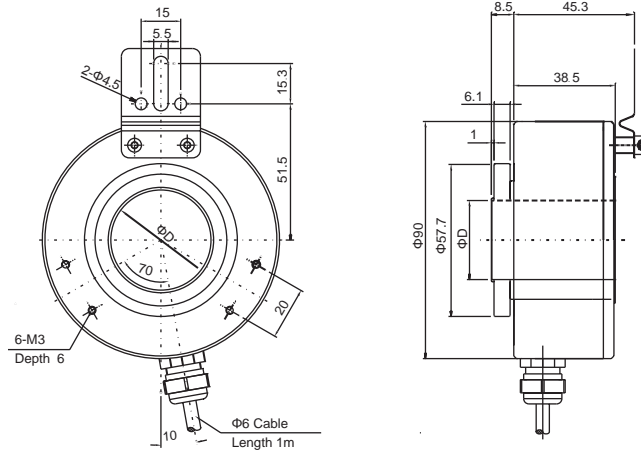

### Order code- Hollow shaft

HAE-90C-XXXX-XXXX  
 Series - economical      A      B C D E

**A resolution**  
1024

**C Shaft diameter**  
B = ø 25 mm  
E = ø 30 mm

**E Connection**  
2 = Radial cable

**B Flange Type**  
4 = Through hollow shaft (lock ring on the shell side)

**D Output/Power supply**  
1 = TTL Line Driver / Power supply 5VDC  
3 = Push-Pull ( without inverted signal ) / Power supply 10~30VDC  
5 = Push-Pull ( with inverted signal ) / Power supply 10~30VDC

## Economical HAE-48 Dedicated servo

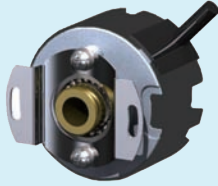

- Universal hollow shaft servo motor encoder
- Connecting pieces connected, easy installation, more lightweight plastic housing
- Straight shaft and hollow shaft two solid cone, stable performance, high reliability
- Widely used in servo motors and other automation industry
- Optional multi-poles



Mechanical characteristics		Electrical parameters	
Max.speed	6000 min <sup>-1</sup>	Output circuit	Drive ( TTL )
Starting torque	0.002 N.m MAX	Power supply	5VDC
Moment of inertia	≤ 20 gm <sup>2</sup>	power consumption	Max.150mA
Shaft load capacity -radial	40 N	Permissible load/channal	Max.20mA
Shaft load capacity -axial	20 N	Pulse frequency	Max.250kHz
Protection class EN 60 529	IP42	signal level- High	Min.2.5V
Operation temperature	-20 - 80°C	signal level- Low	Max.0.5V
Weight	About 0.100 kg	Rising edge time t <sub>r</sub>	Max.100ns
Shock resistance EN 60068-2-29	1000m/s <sup>2</sup> , 6ms	Falling edge time t <sub>f</sub>	Max.100ns
Vibration resistance EN 60068-2-27	100m/s <sup>2</sup> , 10-2000Hz		

## Waveforms

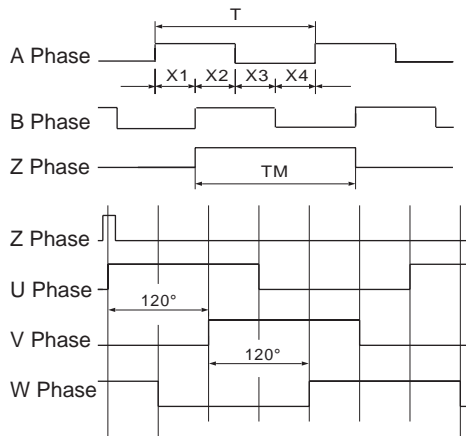

The picture shows the counterclockwise as viewed from the gusset (CCW) rotation of the waveform

Wave ratio

$$X_1+X_2=0.5T \pm 0.1T$$

$$X_2+X_3=0.5T \pm 0.1T$$

Zero signal

$$T_M=1T \pm 0.5T$$

$$T=360/N(N \text{ is the number of output pulses per revolution})$$

From the U-phase positive to Z phase center.  
Accuracy of  $\pm 1^\circ$

U V W Signal  
U V W=4,6,8P

## Terminanl assignment

CCW :

Signal	+5V	0V	A	$\bar{A}$	B	$\bar{B}$	Z	$\bar{Z}$	U	$\bar{U}$	V	$\bar{V}$	W	$\bar{W}$
Thread color	Red	Black	Blue	Blue/Black	Green	Green/Black	Yellow	Yellow/Black	Brown	Brown/Black	Grey	Grey/Black	White	White/Black

# Incremental Encoders

## Straight Hollow shaft Dimensions

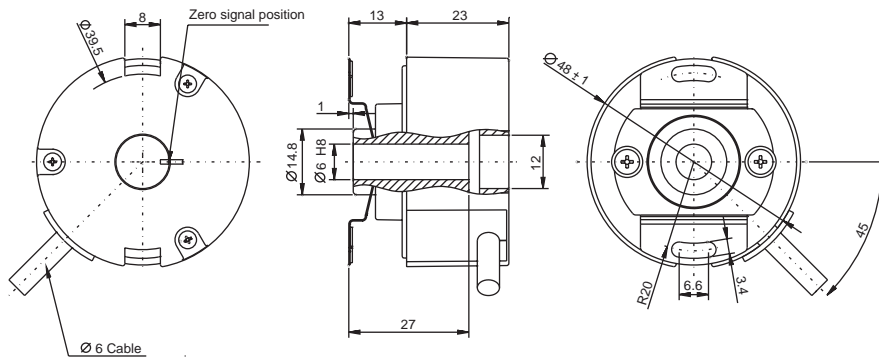

## Hollow cone axis dimensions

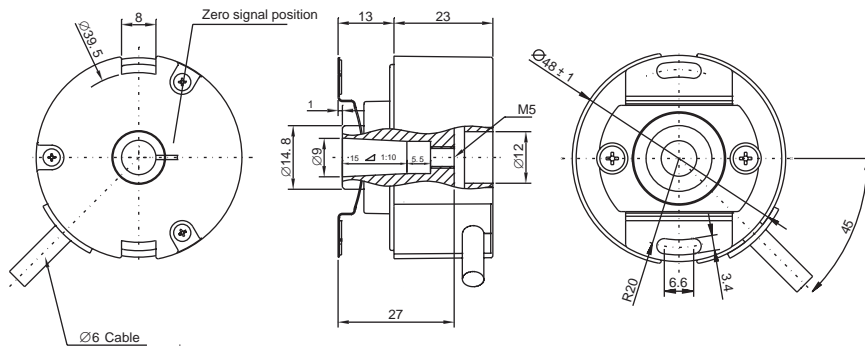

Servo - Order code :

HAE - 4 8 C - X X X X - X X X X - X X

Series - economical A B C D E F

A resolution  
2500

C Shaft diameter  
3 =  $\varnothing$  6 Straight Hollow shaft  
4 =  $\varnothing$  8 Straight Hollow shaft  
5 =  $\varnothing$  9 Hollow cone axis(1 : 10)

E Connection  
2 = Radial cable outlet

B Flange Type  
3 = Flying wing connecting piece 1 = TTL output / 5 VDC power supply

D Output

F Series  
P0 = 0 Pole ( No UVW signals )  
P4 = 4 Pole  
P6 = 6 Pole  
P8 = 8 Pole

## Standard HA-24

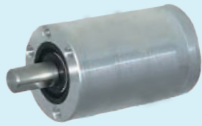

- Miniature encoders shape structure only 24mm, compact ;
- Optional TTL and HTL output ;
- Has a high load bearing capacity and can be used under harsh mechanical environments ;
- Magnetic encoder, the overall protection up to IP65
- Choose from a variety of resolutions, enabling customers to choose to use ;



### Mechanical characteristics

Max.speed	12000 min <sup>-1</sup>
Starting torque	0.02 N.m MAX
Moment of inertia	≤ 20 gcm <sup>2</sup>
Shaft load capacity -radial	80 N
Shaft load capacity -axial	50 N
Protection acc.to EN 60 529	Optional IP65 IP67
Operation temperature	-20 - 80°C
Materials	Shaft : Stainless steel ; Flange、Hoods and housings : aluminium alloy
Weight	About 0.100 kg
shock resistance EN 60068-2-29	3000m/s <sup>2</sup> , 6ms
vibration resistance EN 60068-2-27	300m/s <sup>2</sup> , 10-2000Hz
EX hazardous area certification	Optional 2 and 22

### Electrical parameters

Output circuit	Driver ( TTL )	Push-Pull
Power supply	5VDC	10-30VDC
power consumption	Max. 40mA	Max. 40mA
Permissible load/channal	Max. 30mA	Max. 30mA
Pulse frequency	Max. 20kHz	Max. 200kHz
signal level- High	Min. 2.5V	Min. Ub-2.5V
signal level- Low	Max. 0.5V	Max. 0.5V
Rising edge time t <sub>r</sub>	Max. 1 μs	Max. 1 μs
Falling edge time t <sub>f</sub>	Max. 1 μs	Max. 1 μs
Short circuit protection	No	With
UL-approval	File	
CE approval	EN 61000-6-2, EN 55011 Class B	

Wiring table :

Signal	Ub	GND	A	$\bar{A}$	B	$\bar{B}$	Z	$\bar{Z}$	Shield
Cable (color)	BN	WH	GN	RD	YE	BK	GY	BU	



## Axis - Dimensions

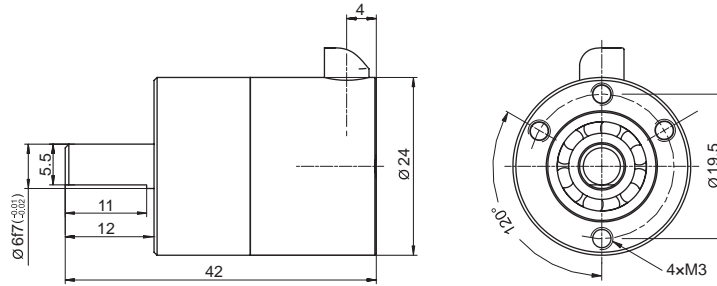

## Shaft Type - Mounting Accessories

Couplings: F10-3020-0606 shaft diameter 6mm more accessories please refer to the attached section

### Axis - Order code :

HA - 2 4 A - X X X X - X X X X  
 Series - Standard      A      B C D E

#### A Resolution

1 ... 64 ; 64 ... 1024 (HTL output only)

#### C axis diameter

2 =  $\varnothing 6 \times 12$  mm

#### E Connection

1 = radial 2 m cable

#### B Flange type

1 = standard flange,  $\varnothing 24$ mm, IP65

#### D output

1 = TTL output / 5 VDC power supply  
 3 = HTL with inverted signals / 5 ... 30 VDC power supply  
 5 = HTL with inverted signal / 10 ... 30 VDC power supply

## Standard HA-40



- Rugged design, dimensions only 40mm, with a high price
- Widely used in mechanical engineering, conveyors and elevators, printing, ceramics and machinery
- Protection class up to IP67
- Operating temperature range -30 ° C ... + 80 ° C
- Resolution up 2500PPR



### Mechanical characteristics

Max.speed	12000 min <sup>-1</sup>
Starting torque	0.02 N.m MAX
Moment of inertia	≤ 20 gcm <sup>2</sup>
Shaft load capacity -radial	80 N
Shaft load capacity -axial	50 N
Protection acc.to EN 60 529	Optional IP65 IP67
Operation temperature	-30 - 80°C
Materials	Shaft : Stainless steel ; Flange, Hoods and housings : aluminium alloy
Weight	About 0.100 kg
shock resistance EN 60068-2-29	3000m/s <sup>2</sup> , 6ms
vibration resistance EN 60068-2-27	300m/s <sup>2</sup> , 10-2000Hz

### Electrical parameters

Output circuit	Driver ( TTL )	Push-Pull
Power supply	5VDC	10-30VDC
power consumption	Max. 40mA	Max. 40mA
Permissible load/channal	Max. 30mA	Max. 30mA
Pulse frequency	Max. 20kHz	Max. 200kHz
signal level- High	Min. 2.5V	Min. Ub-2.5V
signal level- Low	Max. 0.5V	Max. 0.5V
Rising edge time t <sub>r</sub>	Max. 1 μs	Max. 1 μs
Falling edge time t <sub>f</sub>	Max. 1 μs	Max. 1 μs
Short circuit protection	No	With
UL-approval	File	
CE approval	EN 61326-1:2006; EN 61000-6-2:2006 ; EN 61000-6-3:2007	

### Terminanl assignment

Signal	Ub	GND	A	$\bar{A}$	B	$\bar{B}$	Z	$\bar{Z}$	Shield
Cable (color)	BN	WH	GN	RD	YE	BK	GY	VT	
8-pin M12 connector pin holder (pin number)	2	1	3	6	4	7	5	8	

### Top view of the socket

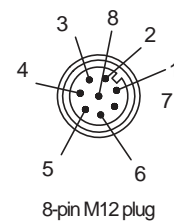

# Incremental Encoders

## Axis - Dimensions

Synchro flange , Ø 6mm Shaft diameter

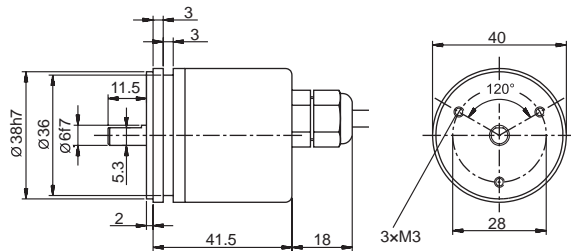

M20 flange

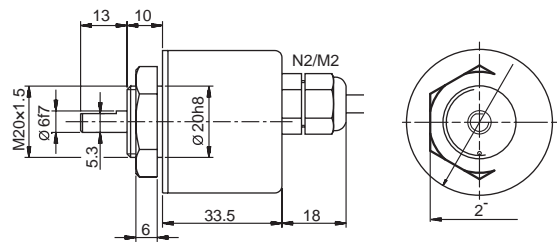

## Sleeve type - Dimensions

Blind hollow shaft type, aperture Ø 6mm

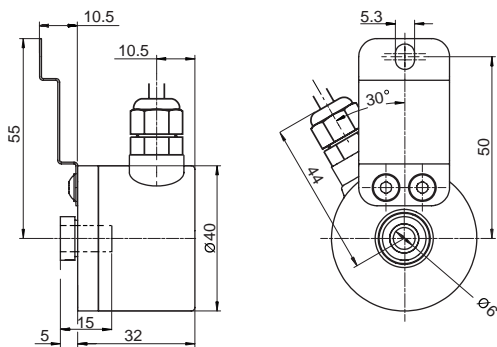

## Mounting Accessories

Cable Connectors: M12 cable connector with 2 m cable EK8-2M / P00

Shaft encoder mounting accessories: aluminum coupling shaft diameter of 6mm F30-3025-0606

Bushings encoder mounting accessories: spring piece connector

For more accessories please refer to the attached section

## Order code- shaft version

HA - 4 0 A - X X X X - X X X X  
**Series - Standard**      A      B C D E

### A Resolution

10 ... 100,125,128 ... 180,200,235,  
 250 ... 300,314,360,400,500 ...600,  
 720 ... 900,1000,1024,1200,1250,  
 1800,2000,2048,2500

### C Shaft diameter

3 =  $\varnothing$  6 x 11,5 mm

### E Connection

1 = 2m axial cable  
 2 = 2 m radial cable  
 8 = axial M12 8-pin plug

### B Flange type

3 = Synchro flange, IP65  
 4 = Synchro flange, IP67  
 5 = M20 Flange, IP65  
 6 = M20 Flange, IP67

### D output

1 = TTL output / 5 VDC power supply  
 3 = HTL (no inverted signal) / 10 ... 30 VDC power supply  
 5 = Push-pull output (with inverted signal) / 5 ... 30 VDC power supply

## Sleeve type - Order code:

HA - 4 0 C - X X X X - X X X X  
**Series - Standard**      A      B C D E

### A Resolution

10,15 ... 100,125,128 ... 180,200,250  
 ... 300,314,360,400,500 ...600,625,  
 635,720 ... 900,1000,1024,1200,1250,  
 1800,2000.2048,2500

### C Shaft diameter

3 =  $\varnothing$  6mm

### E Connection

2 = Radial 2 m cable  
 8 = Axial M12 8-pin plug

### B Flange type

1 = Blind hollow shaft (depth 15 mm)

### D Output

1 = TTL output / 5VDC power supply  
 3 = HTL (no inverted signal) / 10 ... 30 VDC power supply  
 5 = Push-pull output (with inverted signal) / 5 ... 30 VDC power supply

## Standard HA-50



- Rugged industrial standard encoder, compact dimensions only 50mm
- Has a high load bearing capacity, perfect used in various industries
- Protection class up to IP67
- Operating temperature range -30 ° C ... + 80 ° C
- Resolution up 2500PPR



### Mechanical characteristics

Max.speed	12000 min <sup>-1</sup>
starting torque	0.02 N.m MAX
Moment of inertia	≤ 20 gcm <sup>2</sup>
shaft load capacity -radial	120 N
shaft load capacity -axial	70 N
Protection acc.to EN 60 529	Optional IP65 IP67
Operation temperature	-30 - 80°C
Materials	Shaft : Stainless steel ; Flange、Hoods and housings : aluminium alloy
Weight	About 0.350 kg
shock resistance EN 60068-2-29	3000m/s <sup>2</sup> , 6ms
vibration resistance EN 60068-2-27	300m/s <sup>2</sup> , 10-2000Hz

### Electrical parameters

Output circuit	Drive ( TTL )	Push-Pull
Power supply	5VDC	5-30VDC
power consumption	Max. 100mA	Max. 70mA
Permissible load/channel	Max. 40mA	Max. 40mA
Pulse frequency	Max. 20kHz	Max. 200kHz
signal level- High	Min. 2.5V	Min. Ub-2V
signal level- Low	Max. 0.5V	Max. 0.5V
Rising edge time	Max. 200ns	Max. 1 μs
Falling edge time	Max. 200ns	Max. 1 μs
Short circuit protection	With	With
Reverse polarity protection of the power supply	No	With
UL-approval	File	
CE approval	EN 61326-1:2006; EN 61000-6-2:2006 ; EN 61000-6-3:2007	

### Terminanl assignment

Signal	Ub	GND	A	$\bar{A}$	B	$\bar{B}$	Z	$\bar{Z}$	Shield
Cable ( color )	BN	WH	GN	RD	YE	BK	GY	VT	
8-pin M12 connector pin holder (pin number)	2	1	3	6	4	7	5	8	

### Top view of the socket

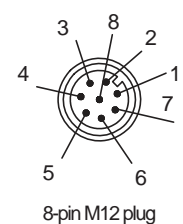

## Axis - Dimensions

Clamping flange, Ø 8mm shaft diameter

M12 Connector Connection

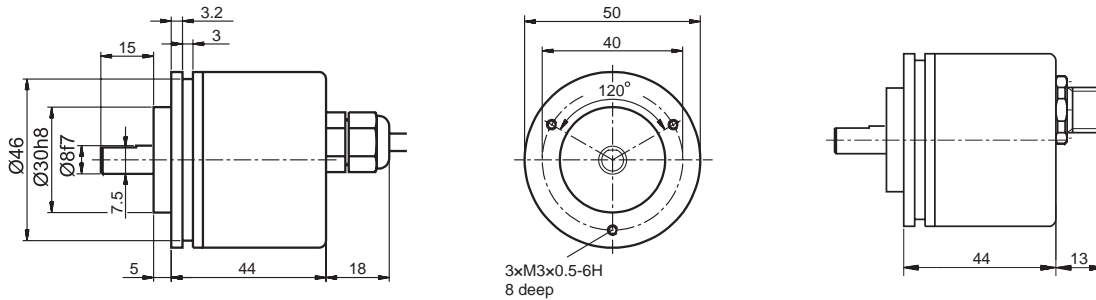

## Shaft encoder mounting accessories

Cable Connectors: M12 cable connector with 2 m cable EK8-2M / P00

Couplings: shaft diameter 8mm F30-3025-0808

For more accessories please refer to the attached section

### Axis - Order code :

HA - 5 0 A - X X X X - X X X X  
**Series - Standard**      A      B C D E

#### A Resolution

4,9,10,15 ... 100,125,128 ... 180,200  
 235,250 ... 300,314,360,400,500 ...  
 600,625,635,720 ... 900,1000,1024  
 1080,1200,1250,1800,2000,2048  
 2500

#### B Flange type

1 = Clamping flange IP65

#### C Shaft diameter

4 = Ø 8 x 15 mm

#### D Output

1 = TTL output / 5VDC power supply  
 3 = Push-Pull (without inverted signal) / 5 ... 30VDC power supply  
 5 = Push-pull output (with inverted signal) / 5 ... 30 VDC power supply

#### E Connection

1 = 2 m axial cable  
 2 = 2 m radial cable  
 8 = Axial M12 8-pin plug

## Incremental Encoders

### Standard HA-58

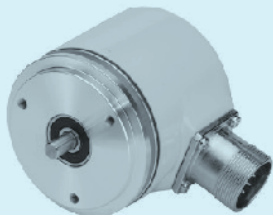

- Shape 58mm, standard industrial design, high noise immunity
- Mechanical and electrical properties with high performance
- Protection class up to IP67, good environmental resistance
- Operating temperature range -40 ° C ... + 80 ° C
- Resolution up 25000PPR, higher resolution may be set, with SinCos output
- Can be used for machine tools, printing, packaging, metallurgy, wind power and other industries



Mechanical characteristics		SinCos Output Electrical characteristics	
Max.speed	12000 min <sup>-1</sup>	Output circuit	SinCos ( 1Vpp )
starting torque	0.2 N.cm MAX	Power supply voltage	5 VDC
Moment of inertia	≤ 20 gcm <sup>2</sup>	Power with inverted signals (no load)	Max.100 mA
shaft load capacity -radial	220 N	Frequency	≤100 kHz
shaft load capacity -axial	120 N	Channel load	Min.120 Ohm
Protection acc.to EN 60 529	Optional IP65/ IP67	Output short circuit protection	Yes
Operation temperature	-40 - 80°C	Reverse polarity connection protection	No
Materials	Shaft: Stainless steel	UL-approval	File
Weight	About 0.25 kg	CE compliant	EN 61326-1:2006
Shock resistance EN 60068-2-29	1000m/s <sup>2</sup> , 6ms		EN 61000-6-2:2006
Vibration resistance EN 60068-2-27	100m/s <sup>2</sup> , 10-2000Hz		EN 61000-6-3:2007
Electrical characteristics			
Output circuit	Drive ( TTL )	Push-Pull	Push-Pull 7272
Power supply	5VDC	10-30VDC	5-30VDC
power consumption	Max. 100mA	Max. 100mA	Max. 70mA
Permissible load/channel	Max. 40mA	Max. 40mA	Max. 40mA
Pulse frequency	Max. 2 MHz	Max. 200kHz	Max. 200kHz
Signal level- High	Min. 2.5V	Min. Ub-1V	Min. Ub-2V
Signal level- Low	Max. 0.5V	Max. 0.5V	Max. 0.5V
Rising edge time t <sub>r</sub>	Max. 1 μs	Max. 1 μs	Max. 1 μs
Falling edge time t <sub>f</sub>	Max. 1 μs	Max. 1 μs	Max. 1 μs
Short circuit protection	Yes	Yes	Yes
Reverse polarity protection	No	Yes	Yes
UL-approval	File		
CE requirement acc.to	EN 61326-1:2006; EN 61000-6-2:2006 ; EN 61000-6-3:2007		

### Terminal assignment

Signal	Ub	GND	A	$\bar{A}$	B	$\bar{B}$	Z	$\bar{Z}$	Shield
Cable color	BN	WH	GN	RD	YE	BK	GY	VT	
M12 connector ,8-pin	2	1	3	6	4	7	5	8	
M23 connector ,12-pin	12	10	5	6	8	1	3	4	

## Top view of the socket

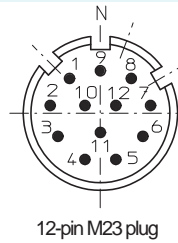
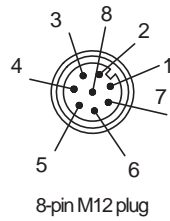

## Mounting Accessories

Cable Connectors: M12 cable connector with 2 m cable

EK8-2M / P00

Shaft encoder couplings: aluminum shaft diameter of 6mm  
aluminum shaft diameter is 10mm

F30-2520-0606

F30-3025-1010

Bushings encoder mounting accessories: spring piece connector

For more accessories please refer to the attached section

## Axis - Dimensions

Synchro flange , Ø 6mm Shaft diameter

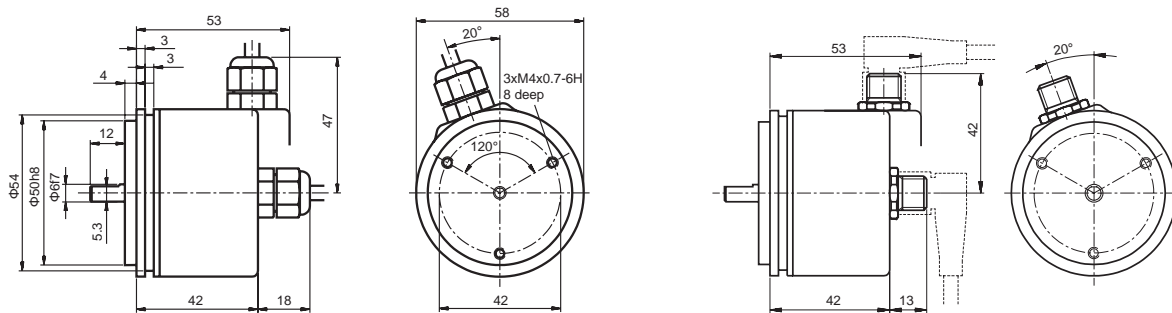

Clamping flange , Ø 10mm Shaft diameter

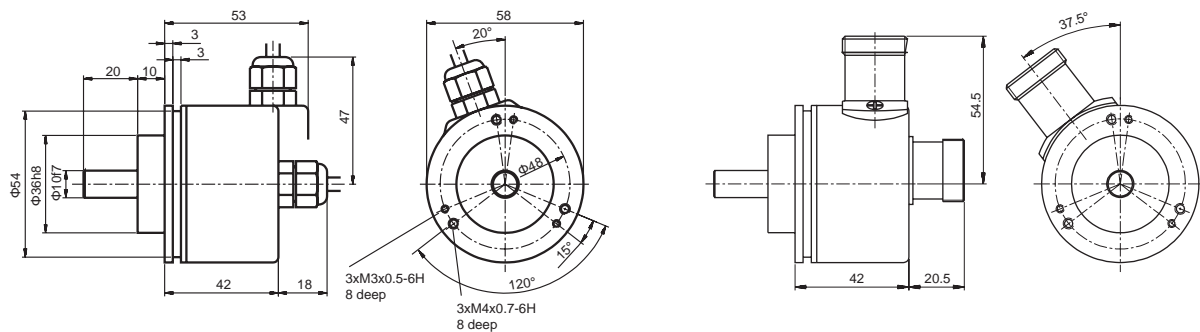



# Incremental Encoders

Synchro flange  $\varnothing 63.5$  mm ,  $\varnothing 9.52$  mm Shaft diameter

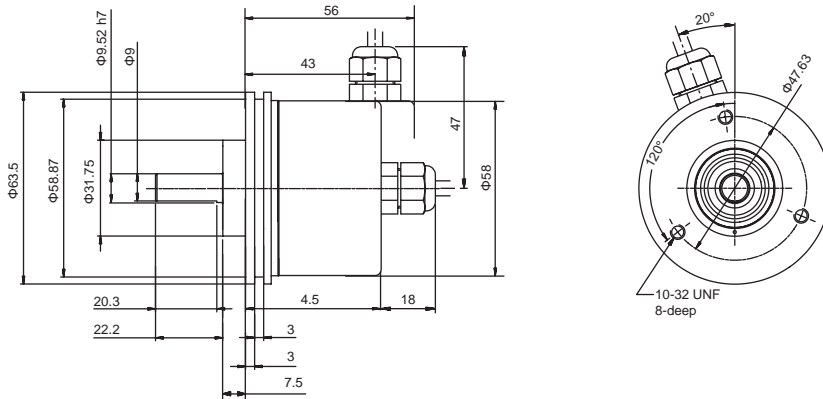

Square flange ,  $\varnothing 9.52$  mm Shaft diameter

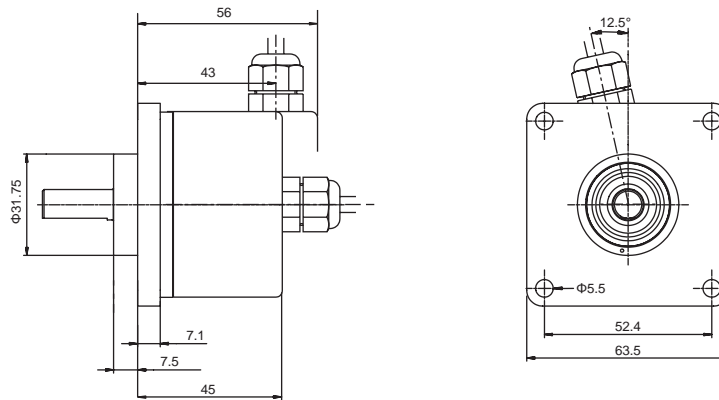

Euro flange  $\varnothing 115$ mm ,  $\varnothing 11$ mm Shaft diameter

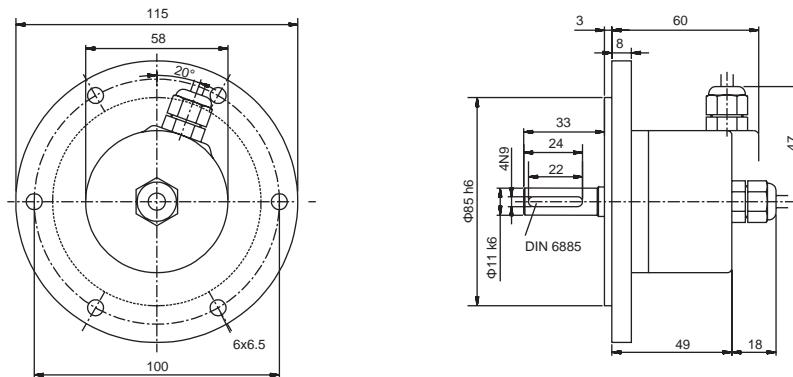

## Hollow shaft

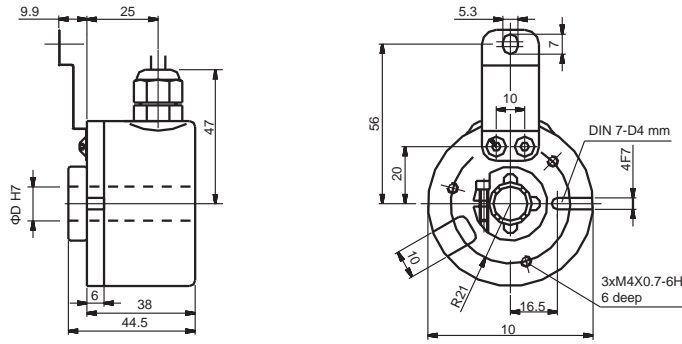

## Blind hollow shaft

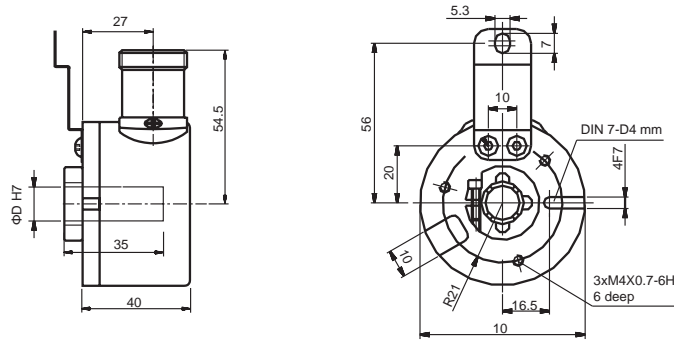

# Incremental Encoders

Order code- shaft version	H A - 5 8 A X - X X X X - X X X X - X						
	Series - Standard A	B	C	D	E	F	G
<b>A Category</b> BLANK = Conventional Series H = High temperature	<b>C Flange Type</b> 1 = Clamping flange , $\varnothing$ 58mm , IP65 2 = Clamping flange , $\varnothing$ 58mm , IP67 3 = Synchro flange , $\varnothing$ 58mm , IP65 4 = Synchro flange , $\varnothing$ 58mm , IP67 5 = Synchro flange , $\varnothing$ 63.5 mm , IP65 6 = Synchro flange , $\varnothing$ 63.5 mm , IP67 7 = Square flange , 63.5 mm , IP65 8 = Square flange , 63.5 mm , IP67 9 = European standard flange , 115 mm , IP65		<b>E Output/power supply</b> 1 = RS422 Output / 5 VDC power supply 2 = RS422/ 10 ... 30 VDC power supply 3 = Push-pull without inverted signals/ 10 ... 30 VDC power supply 4 = 7272 Push-pull output (with inverted signal) / 5 ... 30 VDC power supply 5 = Push-pull output (with inverted signal)/ 10 ... 30 VDC power supply 8 = Sin/Cos 1 Vpp Output / 5 VDC power supply				
<b>B resolution</b> 2,5,15,20,25, .... 100,120, .... 500,512, 600,720, ... 1000,1024,1200,1250, .... 3600,4096,5000, .... 10000 1 Vpp Sin/Cos 1024 2048 Other resolutions on request	<b>D Shaft diameter</b> 2 = $\varnothing$ 6 x 10 mm 5 = $\varnothing$ 10 x 20 mm 6 = $\varnothing$ 9.52 x 20 mm 7 = $\varnothing$ 11 x 33 mm 8 = $\varnothing$ 12 x 30 mm		<b>F Connection</b> 1 = Axial 2 m cable 2 = Radial 2 m cable 3 = Axial M23 12-pin 4 = Radial M23 12-pin 8 = Axial M12 8-pin 9 = Radial M12 8-pin				
	<b>G special features</b> BLANK = no special features						

Order code- Hollow shaft	H A - 5 8 C X - X X X X - X X X X - X						
	Series - Standard A	B	C	D	E	F	G
<b>A Category</b> BLANK = Conventional Series H = High temperature	<b>D Shaft diameter</b> 4 = $\varnothing$ 8 mm 5 = $\varnothing$ 10 mm 6 = $\varnothing$ 12 mm 7 = $\varnothing$ 14 mm 8 = $\varnothing$ 15 mm (Blind Pass only)		<b>F Connection</b> 2 = Radial 2 m cable 4 = Radial M23 12-pin 9 = Radial M12 8-pin				
<b>B resolution</b> 2,5,15,20,25, .... 100,120, .... 500,512, 600,720, ... 1000,1024,1200,1250, .... 3600,4096,5000, .... 10000 1 Vpp Sin/Cos 1024 2048 Other resolutions on request	<b>E output/power supply</b> 1 = RS422 output / 5 VDC power supply 2 = RS422 / 10 .. 30 VDC power supply 3 = Push-pull without inverted signals / 10 ... 30 VDC power supply 4 = 7272 Push-pull without inverted signals / 5 ... 30 VDC power supply 5 = Push-pull without inverted signals / 10 ... 30 VDC power supply 8 = Sin/Cos 1 Vpp output / 5 VDC power supply		<b>G special features</b> BLANK = No special features				
<b>C Flange Type</b> 1 = Blind hollow shaft 3 = Through hollow shaft , IP65 8 = Flying wing with spring leaves , IP65							

## Standard HA-58AS Stainless Steel



- Shape 58mm, stainless steel shell, through a rigorous testing hygienic design
- Resistance to salt spray corrosion, available in acid, alkali environment
- Protection class up to IP67
- Operating temperature range -20 ° C ... + 80 ° C
- Resolution up 25000PPR, has antibacterial, self-cleaning certified for use in the food industry



### Mechanical characteristics

Max.speed	6000 min <sup>-1</sup>
starting torque	0.02 N.m MAX
Moment of inertia	≤ 20 gcm <sup>2</sup>
shaft load capacity -radial	100 N
shaft load capacity -axial	100 N
Protection acc.to EN 60 529	Optional IP65 IP67
Operation temperature	-20 - 80°C
Materials	Shaft, flange, Shell : stainless steel
Weight	About 0.600 kg
shock resistance EN 60068-2-29	3000m/s <sup>2</sup> , 6ms
vibration resistance 60068-2-27	300m/s <sup>2</sup> , 10-2000Hz

### Electrical parameters

Output circuit	Drive ( TTL )	Push-Pull
Power supply	5VDC/10-30VDC	10-30VDC
power consumption	max. 100mA	max. 100mA
Permissible load/channal	max. 40mA	max. 40mA
Pulse frequency	max. 20kHz	max. 200kHz
signal level- High	min. 2.5V	min. Ub-1V
signal level- Low	max. 0.5V	max. 0.5V
Rising edge time t <sub>r</sub>	max. 200 ns	max. 1 μs
Falling edge time t <sub>f</sub>	max. 200 ns	max. 1 μs
Short circuit protection	Have	Have
Reverse polarity protection of the power supply	No	Have
UL-approval	File	
CE approval	EN 61326-1:2006; EN 61000-6-2:2006 ; EN 61000-6-3:2007	

### Terminanl assignment

Signal	Ub	GND	A	Ā	B	B̄	Z	Z̄	Shield
Cable ( color )	BN	WH	GN	RD	YE	BK	GY	VT	

## Axis - Dimensions

Clamping flange, Ø 10 mm shaft diameter , axial cable

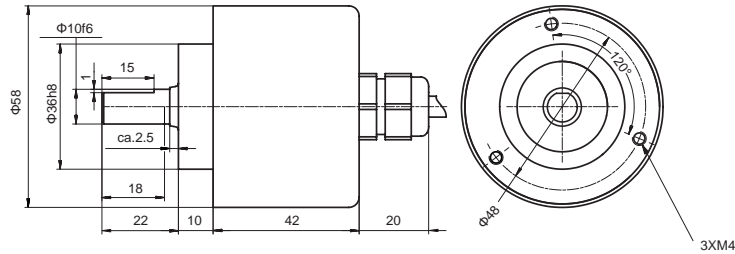

Clamping flange, Ø 10 mm shaft diameter, radial cable

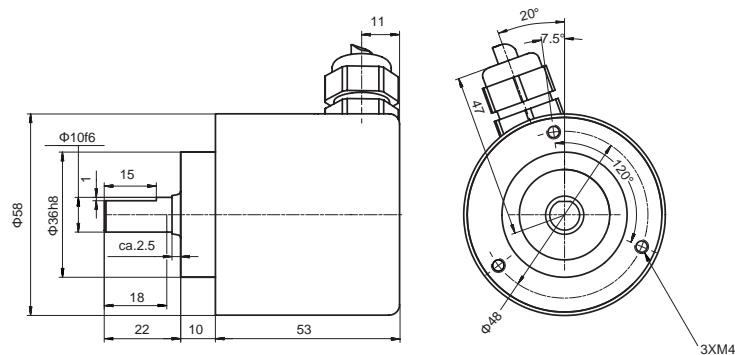

Axis - Order code :

HA - 5 8 AS - X X X X - X X X X  
**Series - Standard**      A      B C D E

**A Resolution**

2,5,15,20,25, .... 100,120, .... 500,512,  
 600,720, ... 1000,1024,1200,1250, ....  
 3600,4096,5000, .... 10000, 12500,  
 20000,25000

**C Shaft diameter**

5 = Ø 10 x 20 mm

**E Connection**

1 = Axial 2 m cable ( TPE )  
 2 = Radial 2 m cable ( TPE )

**B Flange type**

1 = Clamping flange IP67

**D output**

1 = TTL output / 5 VDC power supply  
 2 = TTL line driver / 10 ... 30 VDC power supply  
 3 = Push-pull without inverted signal / 10 ... 30 VDC power supply  
 5 = Push-pull output (with inverted signal) / 10 ... 30 VDC power supply

## Standard Large hollow shaft HA-80C



- Rugged industrial encoders, diameter 80mm
- Through hollow shaft type, maximum aperture of 25mm, can be used in harsh environments under mechanical
- Protection class up to IP67
- Operating temperature range -40 ° C ... + 80 ° C
- Resolution up 3840PPR



### Mechanical characteristics

Max.speed	6000 min <sup>-1</sup>
Starting torque	0.02 N.m MAX
Moment of inertia	≤ 20 gcm <sup>2</sup>
Shaft load capacity -radial	200 N
Shaft load capacity -axial	100 N
Protection acc.to EN 60 529	Optional IP65 IP67
Operation temperature	-40 - 80°C
Materials	Shaft : Stainless steel ; Flange, Hoods and housings : aluminium alloy
Weight	About 0.720 kg
shock resistance	3000m/s <sup>2</sup> , 6ms
vibration resistance	300m/s <sup>2</sup> , 10-2000Hz

### Electrical characteristics

Output circuit	Drive ( TTL )	Push-Pull	Push-Pull ( 7272 )
Power supply	5VDC	10-30VDC	5-30VDC
power consumption	max. 100mA	max.100mA	max. 70mA
Permissible load/channel	max. 40mA	max. 40mA	max. 40mA
Pulse frequency	max. 20kHz	max. 200kHz	max. 200kHz
signal level- High	min. 2.5V	min. Ub-1V	min. Ub-2V
signal level- Low	max. 0.5V	max. 0.5V	max. 0.5V
Rising edge time tr	max. 200ns	max. 1 μs	max. 1 μs
Falling edge time tr	max. 200ns	max. 1 μs	max. 1 μs
Short circuit protection	YES	YES	YES
Reverse polarity protection	No	YES	YES
UL-approval	File		
CE approval	EN 61326-1:2006; EN 61000-6-2:2006 ; EN 61000-6-3:2007		

### Terminanl assignment

signal	Ub	GND	A	$\bar{A}$	B	$\bar{B}$	Z	$\bar{Z}$	Shield
Cable ( color )	BN	WH	GN	RD	YE	BK	GY	VT	
8-pin M12 connector	2	1	3	6	4	7	5	8	

### Top view of the socket

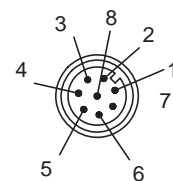

8-pin M12

# Incremental Encoders

## Hollow shaft - Dimensions

Through hollow shaft

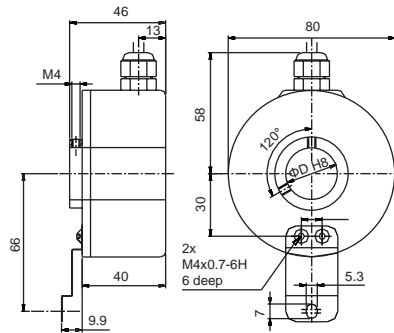

## Mounting Accessories

Cable Connectors: M12 cable connector with 2 m cable

EK8-2M / P00

Bushings encoder mounting accessories: spring piece connector

For more accessories please refer to the attached section

Trolley

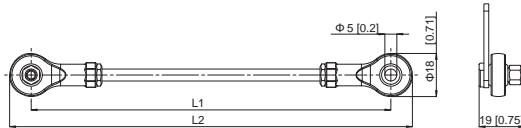

L1= 70 mm , ( other lengths on request ) FL-0070

## Order code- Hollow shaft

HA - 80 C - X X X X - X X X X  
 Series - Standard      A      B C D E

### A Resolution

512,1000,1024,2048,2500,3600,  
3840

### B Flange type

3 = through hollow shaft  
(lock ring flange measurement) IP65

### C Shaft diameter

5 =  $\varnothing$  10 mm  
6 =  $\varnothing$  12 mm  
7 =  $\varnothing$  14 mm  
8 =  $\varnothing$  15 mm  
9 =  $\varnothing$  16 mm  
A =  $\varnothing$  20 mm  
B =  $\varnothing$  25 mm

### D output/power supply

1 = TTL output / 5 VDC power supply  
2 = TTL line driver / 5 ... 30 VDC power supply  
3 = HTL no inverted signal / 10 ... 30 VDC power supply  
4 = 7272 push-pull output (with inverted signal)  
/ 5 ... 30 VDC power supply  
5 = Push-pull output (with inverted signal) / 10 ... 30 VDC  
power supply

### E Connection

2 = Radial 2 m cable  
9 = Radial M12 8-pin

## Standard heavy-duty HA-A0C



- Outside diameter of 100mm heavy duty large hollow series
- The maximum aperture of 45mm, can be used in harsh mechanical environments
- Protection class up to IP65, Operating temperature range -40 ° C ... + 80 ° C
- Can be used for a variety of ports, metallurgy, mining machinery and various automation industry
- Resolution up 10000PPR, have SIN / COS output



Mechanical characteristics		SinCos output electrical characteristics	
Max.speed	3600 min <sup>-1</sup>	Output circuit	SinCos ( 1Vpp )
Starting torque	0.17 N.m MAX	Power supply voltage	5 VDC
Moment of inertia	≤ 24 gcm <sup>2</sup>	Power with inverted signals (no load)	Max 100 mA
Shaft load capacity -radial	200 N	Frequency	≤100 kHz
Shaft load capacity -axial	100 N	Channel load	Min 120 Ohm
Protection acc.to EN 60 529	Optional IP65 IP67	Output short circuit protection	Yes
Operation temperature	-40 - 80°C	Reverse polarity protection	No
Materials	Shaft : Stainless steel ; Flange, Hoods and housings : aluminium alloy	UL-approval	File
Weight	About 1.000 kg	CE compliant	EN 61326-1:2006
Shock resistance EN 60068-2-29	1000m/s <sup>2</sup> , 6ms		EN 61000-6-2:2006
Vibration resistance EN 60068-2-27	100m/s <sup>2</sup> , 10-2000Hz		EN 61000-6-3:2007

Electrical characteristics			
Output circuit	Drive ( TTL )	Push-Pull	Push-Pull ( 7272 )
Power supply	5VDC	10-30VDC	5-30VDC
power consumption	max. 150mA	max. 150mA	max. 150mA
Permissible load/channel	max. 30mA	max. 30mA	max. 30mA
Pulse frequency	max. 20kHz	max. 200kHz	max. 200kHz
signal level- High	min. 2.5V	min. Ub-1V	min. Ub-1V
signal level- Low	max. 0.5V	max. 0.5V	max. 0.5V
Rising edge time tr	max. 200 ns	max. 1 μs	max. 1 μs
Falling edge time tr	max. 200 ns	max. 1 μs	max. 1 μs
Short circuit protection	Yes	Yes	Yes
Reverse polarity protection	No	Yes	Yes
UL-approval	File		
CE-approval	EN 61326-1:2006; EN 61000-6-2:2006 ; EN 61000-6-3:2007		

### Terminanl assignment

signal	Ub	GND	A	$\bar{A}$	B	$\bar{B}$	Z	$\bar{Z}$	Shield
Cable color	BN	WH	GN	RD	YE	BK	GY	VT	
M12 connector 8-pin	2	1	3	6	4	7	5	8	
M23 connector 12-pin	12	10	5	6	8	1	3	4	



# Incremental Encoders

## Top view of the socket



## hollow shaft - Dimensions

Through hollow shaft

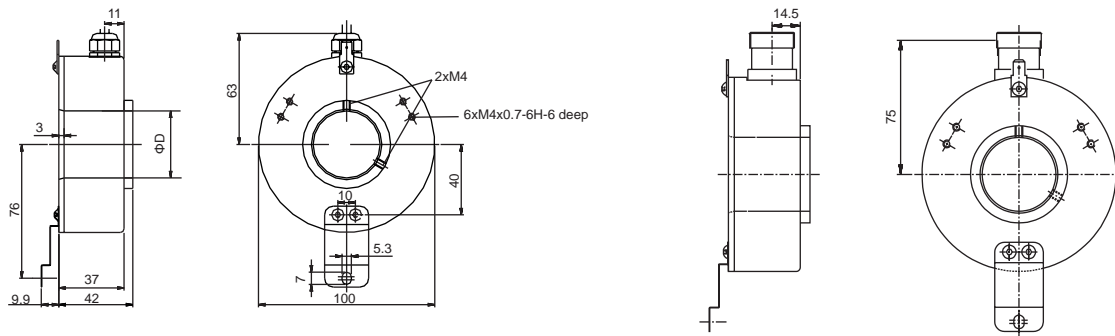

## Mounting Accessories

Cable Connectors: M12 cable connector with 2 m cable  
encoder mounting accessories: spring piece connector

EK8-2M / P00

Trolley

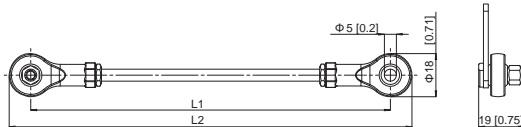

L1= 70 mm , ( Other lengths on request )

FL-0070

## Order code- Hollow shaft

HA - A0 C - X X X X - X X X X - X  
Series - Standard      A      B C D E F

### A Resolution

512,1000,1024,2048,2500,3600,  
4096,4500,5000, .... 8192,10000  
1 Vpp Sin/Cos 1024 2048

### B Flange type

3 = Through hollow shaft  
4 = Through hollow shaft (lock ring on the shell side)

### C Shaft diameter

A =  $\phi$  20 mm  
B =  $\phi$  25 mm  
C =  $\phi$  25.4 mm  
E =  $\phi$  30 mm  
F =  $\phi$  35 mm  
G =  $\phi$  38 mm  
H =  $\phi$  40 mm  
J =  $\phi$  42 mm  
L =  $\phi$  45 mm

### D output/power supply

1 = RS422 output / 5 VDC power supply  
2 = RS422 output / 10 ... 30 VDC power supply  
3 = HTL no inverted signal / 10 ... 30 VDC power supply  
4 = 7272 push-pull output (with inverted signal) / 5 ... 30 VDC power supply  
5 = Push-pull output (with inverted signal) / 10 ... 30 VDC power supply  
8 = SinCos 1Vpp output / 5 VDC power supply

### E Connection

2 = Radial 2 m cable      4 = Radial M23 12-pin  
9 = Radial M12 8-pin

### F Special Function

BLANK = no special features

## Standard heavy-duty large bushes HA-145C



- Rugged industrial standard encoder, shape 145mm, maximum aperture of 72mm
- Has a high load bearing capacity and can be used under harsh mechanical environments
- Protection IP65
- Operating temperature range -40 ° C ... + 80 ° C
- Resolution up 2500PPR



### Mechanical characteristics

Max.speed	1600 min <sup>-1</sup>
Starting torque	0.02 N.m MAX
Moment of inertia	≤ 20 gcm <sup>2</sup>
Shaft load capacity -radial	200 N
Shaft load capacity -axial	100 N
Protection acc.to EN 60 529	Optional IP65 IP67
Operation temperature	-40 - 80°C
Materials	Shaft : Stainless steel ; Flange, Hoods and housings : aluminium alloy
Weight	About 2.000 kg
shock resistance EN 60068-2-29	3000m/s <sup>2</sup> , 6ms
vibration resistance EN 60068-2-27	300m/s <sup>2</sup> , 10-2000Hz

### Electrical parameters

Output circuit	Drive ( TTL )	Push-Pull
Power supply	5VDC	10-30VDC
power consumption	max. 100mA	max. 70mA
Permissible load/channel	max. 40mA	max. 40mA
Pulse frequency	max. 20kHz	max. 200kHz
signal level- High	min. 2.5V	min. Ub-2V
signal level- Low	max. 0.5V	max. 0.5V
Rising edge time t <sub>r</sub>	max. 200 ns	max. 1 μs
Falling edge time t <sub>f</sub>	max. 200 ns	max. 1 μs
Short circuit protection	Have	Have
Reverse polarity protection of the power supply	No	Have
CE-approval	EN 61326-1:2006; EN 61000-6-2:2006 ; EN 61000-6-3:2007	

### Terminal assignment

Signal	Ub	GND	A	$\bar{A}$	B	$\bar{B}$	Z	$\bar{Z}$	Shield
Cable ( color )	BN	WH	GN	RD	YE	BK	GY	VT	
8-pin M12 connector pin holder (pin number)	2	1	3	6	4	7	5	8	
12-pin M23 connector header (pin number)	12	10	5	6	8	1	3	4	

# Incremental Encoders

## Top view of the socket

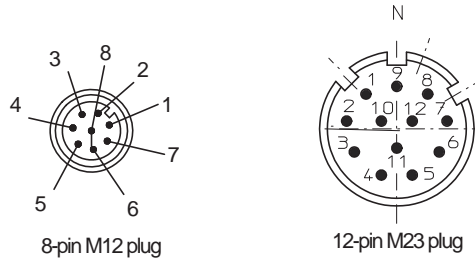

## Sleeve type - Dimensions

Through hollow shaft outlet connection

Through-hole connector sleeve

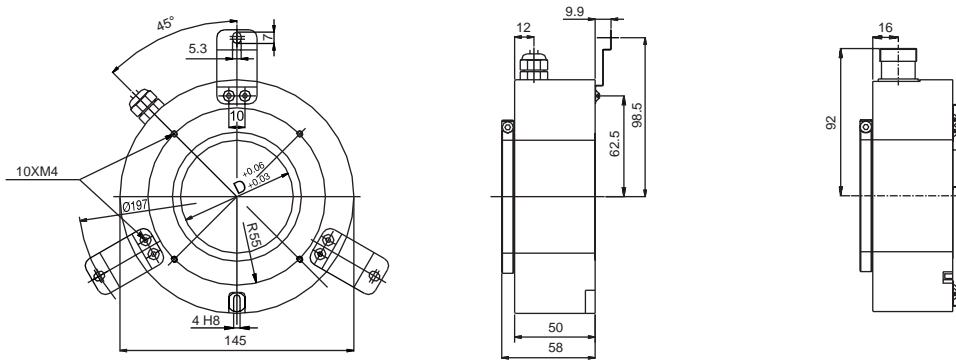

## Mounting Accessories

Cable Connectors: M12 cable connector with 2 m cable

EK8-2M/P00

Bushings encoder mounting accessories: spring piece connector

Trolley

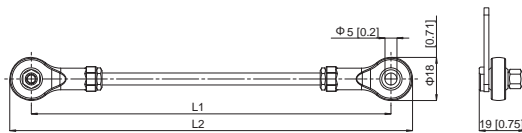

L1= 70 mm , ( Other lengths can be set ) FL-0070

## Order code- Hollow shaft

HA - 145 C - X X X X - X X X X  
**Series - Standard**      A      B C D E

**A Resolution**  
1024,2500

**C Shaft diameter**  
M =  $\varnothing$  48 mm  
N =  $\varnothing$  50 mm  
P =  $\varnothing$  55 mm  
Q =  $\varnothing$  60 mm  
R =  $\varnothing$  65 mm  
S =  $\varnothing$  72 mm

**D output**  
1 = TTL output / 5 VDC power supply  
3 = HTL no inverted signal / 10 ... 30 VDC power supply  
5 = Push-pull output (with inverted signal) / 10 ... 30 VDC power supply

**B Flange type**  
4 = Through hollow shaft (lock ring on the shell side) IP65

**E Connection**  
2 = Radial 2 m cable  
4 = Radial M23 12-pin plug  
9 = Radial M12 8-pin plug

## HA-48 standard dedicated servo

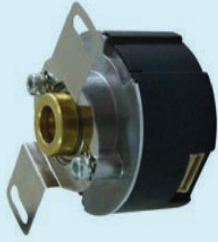

- Universal hollow shaft servo motor encoder
- Wings connecting pieces connected, easy installation
- Straight shaft and hollow shaft two solid cone, stable performance, high reliability
- Widely used to measure the speed of the servo motor and the rotor magnetic pole position
- Optional multi-poles



Mechanical characteristics		Electrical parameters	
Max.speed	6000 min <sup>-1</sup>	Output circuit	Drive ( TTL )
Starting torque	0.005 N.m MAX	Power supply	5VDC
Moment of inertia	≤ 20 gcm <sup>2</sup>	power consumption	Max.150mA
Shaft load capacity -radial	40 N	Permissible load/channal	Max.20mA
Shaft load capacity -axial	20 N	Pulse frequency	Max.250kHz
Protection acc.to EN 60 529	IP50	signal level- High	Min.2.5V
Operation temperature	-20 - 80°C	signal level- Low	Max.0.5V
Weight	About 0.300 kg	Rising edge time t <sub>r</sub>	Max.100ns
shock resistance EN 60068-2-29	1000m/s <sup>2</sup> , 6ms	Falling edge time t <sub>f</sub>	Max.100ns
vibration resistance EN 60068-2-27	100m/s <sup>2</sup> , 10-2000Hz		

## Waveforms

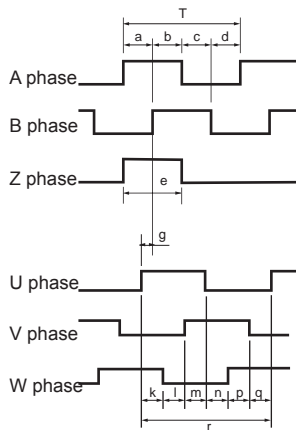

The picture shows the counterclockwise as viewed from the gusset (CCW) rotation of the waveform

Wave ratio  $a.b.c.d=T/4\pm T/8$

Zero signal  $e=T\pm T/2$

$T = 360 / N$  (N is the number of output pulses per revolution)

A, B phase and Z-phase position relationship not specified

g: U phase from a positive to a Z-phase center. Accuracy of  $\pm 1^\circ$  (mechanical angle)

U V W cycle and phase

Poles	k,l,m,n,p,q	r
4	30±1°	180°
6	20±1°	120°
8	15±1°	90°

## Terminanl assignment

CCW :

signal	+5V	0V	A	$\bar{A}$	B	$\bar{B}$	Z	$\bar{Z}$	U	$\bar{U}$	V	$\bar{V}$	W	$\bar{W}$
The line color	Red	Black	Blue	Blue/Black	Green	Green/Black	Yellow	Yellow/Black	Brown	Brown/Black	Grey	Grey/Black	White	White/Black

## Straight Hollow shaft - Dimensions

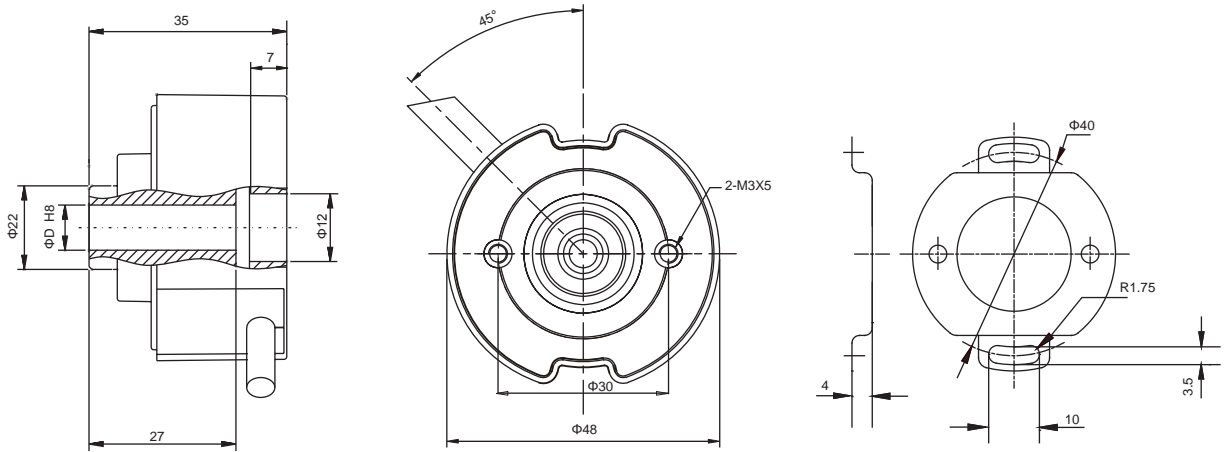

## Hollow taper - Dimensions

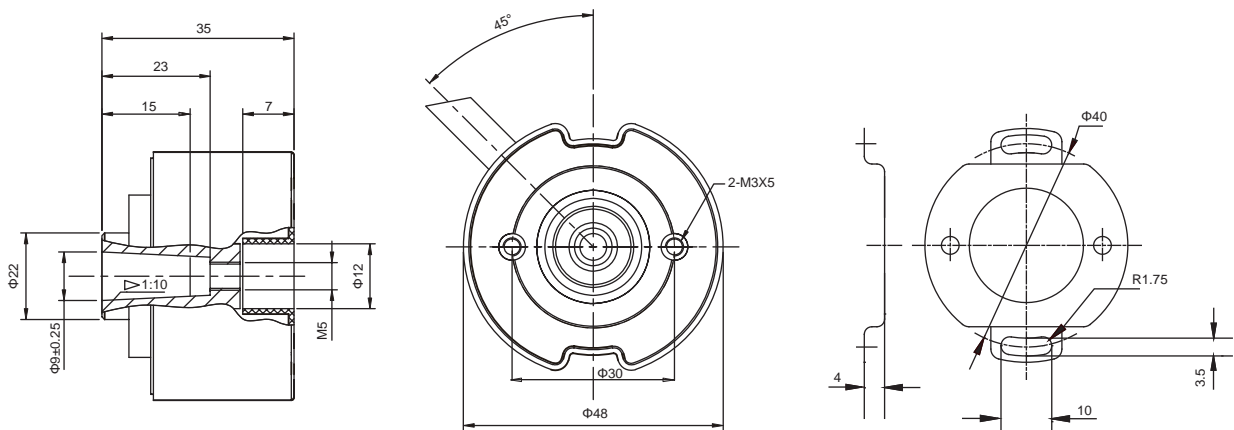

### Servo - Order code :

HA - 4 8 C - X X X X - X X X X - X X

Series - Standard	A	B	C	D	E	F
-------------------	---	---	---	---	---	---

#### A resolution

1024,1250,2048,2500,5000

#### B Flange type

3 = Flying wing connecting piece ( 40mm)

Other sizes can be ordered spring leaf

#### C Shaft diameter

3 =  $\varnothing$  6 straight hollow shaft  
 4 =  $\varnothing$  8 straight hollow shaft  
 5 =  $\varnothing$  9 hollow cone axis (1:10)  
 6 =  $\varnothing$  7 hollow cone axis (1:10)

#### D output

1 = TTL output / 5 VDC power supply

#### E Connection

2 = Radial cable outlet

#### F series

P0 = 0 pole (no UVW signals)  
 P4 = 4 pole  
 P6 = 6 pole  
 P8 = 8 pole  
 P10 = 10 pole

## Absolute lap parallel HB2-58



- Shape 58mm, standard industrial design, cost-effective
- Wide operating temperature range -40 ° C ... + 85 °
- Parallel, push-pull circuit
- Optical sensor technology, resolution up to 16 bits
- Optional binary, Gray code or Gray code output I
- Optional pre-function, you can set the zero position, easy installation and commissioning of the encoder



Mechanical characteristics		Parallel electrical parameters			
Max.speed	12000 min <sup>-1</sup>	Interface Type	Parallel Output		
Starting torque	0.03 N.m MAX	Output circuit	Push-Pull		
Moment of inertia	≤ 30 gcm <sup>2</sup>	Each channel allows the load	Max.20 mA		
Shaft load capacity -radial	110 N	Output frequency	Max.200 kHz		
Shaft load capacity -axial	40 N	Code	Binary/Gray/Gray-Excess		
Protection acc.to EN 60 529	Optional IP65 IP67	singleturn resolution	Max.16bits		
Operation temperature	-40 - 85°C	linearity	±½ LSB (12 bit), ± 2 LSB (16 bit)		
Materials	Shaft : Stainless steel ; Flange, Hoods and housings : aluminium alloy	Signal level is high	Ub		
Weight	About 0.285 kg	Signal level is low	Max.1.8 V		
shock resistance EN 60068-2-29	1000m/s <sup>2</sup> , 6ms	Internal data refresh rate	< 3 μs		
vibration resistance EN 60068-2-27	100m/s <sup>2</sup> , 10-2000Hz	Start time	< 1 s		
Mechanical life Fa/Fr	40/60    40/80    40/110 247      104      40	Control input	Input voltage> 4.5 V effective		
GE parameters		resolution, order code table			
Power supply	10 ... 30 VDC	resolution	Order code Gray	Order code Binary	Order code Gray-Excess
power consumption	A typical 180 mA				
Drive circuit	Push-Pull	360 (9 Bit)	--	--	D09
Start time	< 250 ms	1024 (10 Bit)	G10	B10	
Output short circuit protection	With	4096 (12 Bit)	G12	B12	
Reverse polarity protection of the power supply	With	8192 (13 Bit)	G13	B13	
UL-approval	File				
CE compliant	EN 61000-6-4 ; EN61000-6-2				
MTTF	13.5 years ( 40°C 时)				

### Terminanl assignment

Signal	Ub	GND	1	2	3	4	5	6	7	8	9	10	11	12	13	14	15	16	SET	DIR
Cable ( Color code )	White /Red	Brown /Red	Brown	White	Green	Yellow	Grey	Pink	Red	Blue	Black	Purple	Grey /Pink	Red /Blue	White /Green	Brown /Green	White /Yellow	Yellow /Brown	Pink /Brown	White /Blue
M23 16 针 <sup>1</sup>	15	16	1	2	3	4	5	6	7	8	9	10	11	12	-	-	-	-	14	13
M23 16 针 <sup>2</sup>	15	16	1	2	3	4	5	6	7	8	9	10	11	12	13	-	-	-	-	14

1 ) resolution ≤ 12 bit Only Gray code output Signal: 1 = LSB ; 2 =LSB+1; 3 = LSB+3; ... 16 = MSB

2 ) resolution ≤ 13 bit

SET: SET input when the input high, the current position is set to zero, the response time of >100 ms

DIR: Counting direction to change the input when the input is floating or shorted to GND, the encoder counts up direction is CW;

When the input is always at a high level; encoder counts up direction CCW

## Top view of the socket

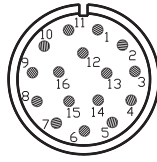

M23 16-pin plug

## Mounting Accessories

Shaft encoder mounting accessories: Aluminum coupling shaft diameter of 6mm

F30-3025-0606

Spring steel coupling shaft diameter of 10mm

F20-5025-1010

Bushings encoder mounting accessories: spring piece connector

For more accessories please refer to the attached section

## Axis - Dimensions

Clamping flange, Ø10mm shaft diameter

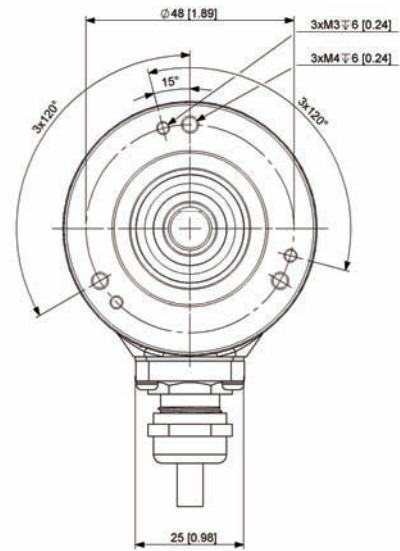
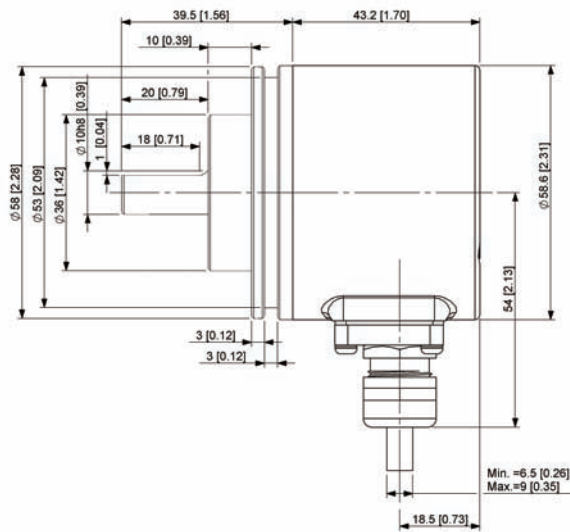

Synchro flange Ø 6mm shaft diameter

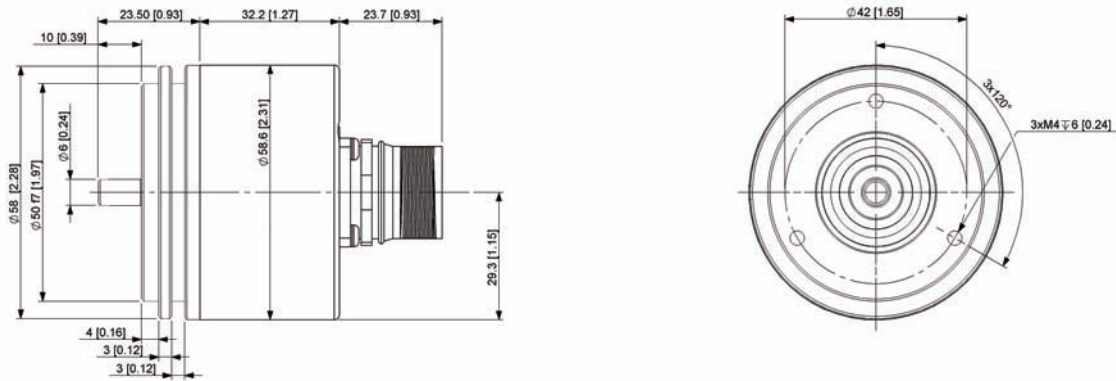

## Sleeve type - Dimensions

Blind hollow shaft

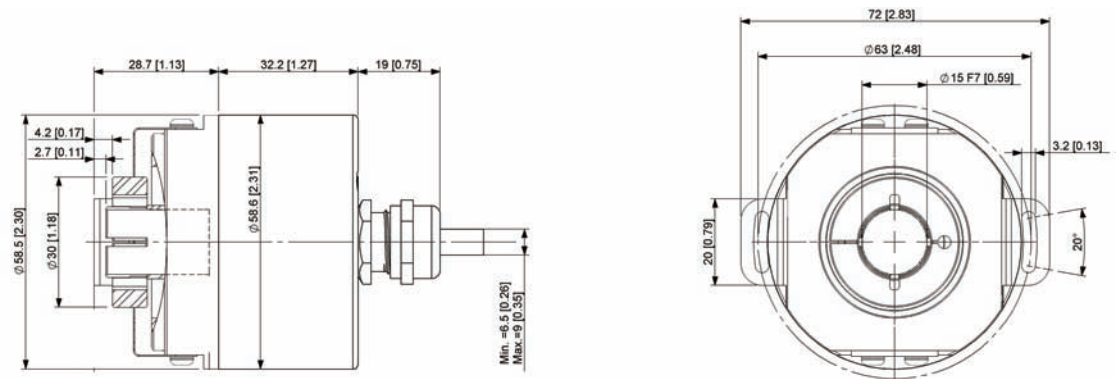

Blind hollow shaft depth of 30 mm



# Absolute Encoders-Singleturn

## Order code- shaft version

HB2 - 5 8 A - X X X - X X X X - X  
**Series - Standard**    A    B    C    D    E    F    G

### A Code

B = Binary  
 G = Gray  
 D = Gray-Excess

### C Flange Type

1 = Clamping flange , IP65  
 2 = Clamping flange , IP67  
 3 = Synchro flange , IP65  
 4 = Synchro flange , IP67

### E output / Power supply

4 = Parallel Output / 10 ... 30 VDC power supply

### G function

BLANK = No additional features

### F Connection

1 = Axial 1 m cable  
 2 = Radial 1 m cable  
 3 = Axial M23 connectors  
 4 = Radial M23 connectors

### B singleturn resolution

Referring to the resolution list

### D Shaft diameter

2 = ø 6 x 10mm  
 5 = ø 10 x 20mm

## Order code- Hollow shaft

HB2 - 5 8 C - X X X - X X X X - X  
**Series - Standard**    A    B    C    D    E    F    G

### A Code

B = Binary  
 G = Gray  
 D = Gray-Excess

### C Flange Type

8 = Flying wing with fixed connectors , IP65

### E output / Power supply

4 = Parallel Output / 10 ... 30 VDC power supply

### G function

BLANK = No additional features

### F Connection

2 = Radial 1 m cable  
 4 = Radial M23 connectors

### D singleturn resolution

Referring to the resolution list

## Absolute lap SSI HB1-58



- Shape 58mm, standard industrial design, may be accompanied by incremental signal output
- Wide operating temperature range -40 ° C ... + 85 °
- SSI synchronous serial interface output can be preset initial value, counting direction can be changed
- Lap up to 16 bits resolution
- High degree of protection up to IP67
- With a cable outlet, M12, M23 multiple connectivity options to choose from



Mechanical characteristics		SSI interface parameters	
Max.speed	12000 min <sup>-1</sup>	Supply voltage	5-30 VDC
Starting torque	0.03 N.m MAX	Power	50 mA
Moment of inertia	≤ 30 gcm <sup>2</sup>	Interface Type	SSI Synchronous Serial Interface
Shaft load capacity -radial	110 N	Drive circuit	RS 422
Shaft load capacity -axial	40 N	Input clock frequency	100 kHz ... 2 MHz
Protection acc.to EN 60 529	Optional IP65 IP67	Monostable time	> 25µs
Operation temperature	-40 - 85°C	Start time	< 250 ms
Materials	Shaft: Stainless steel	Code	Gray code / binary code
	Housing: Aluminum	singleturn resolution	Max 16 bits
	Flange: stainless steel	Function	Can be prefabricated (1); to change the counting direction (2)
Weight	About 0.300 kg	Output short circuit protection	With
shock resistance EN 60068-2-29	1000m/s <sup>2</sup> , 6ms	Reverse polarity connection protection	With
vibration resistance EN 60068-2-27	100m/s <sup>2</sup> , 10-2000Hz	UL-approval	File 251481
Mechanical life Fa/Fr	40/60 40/80 40/110	CE Compliance	EN 61000-6-4:2007-09; EN61000-6-2:2005
	247 104 40		
Explosion levels	-	( 1 ) Pre-function can be set by the initial position of the encoder, when SET lines and power are short, time is more than one second , The encoder will encode the current value is zero; the corresponding time 100 ms; input impedance 110 kΩ	
<b>Additional incremental output ( A/B/Z )</b>		( 2 ) the counting direction can be changed by the direction of the encoder function , When the DIR and power lines suspended or negative short-circuited, the encoder shaft by CW direction of rotation, the data output is increased ; When the DIR line with the positive supply shorted by CCW rotation encoder, the data output is increased ;	
Output	TTL/HTL		
Resolution	1024,2048,4096 ppr		
Output channels	A, $\bar{A}$ ; B, $\bar{B}$ ; Z, $\bar{Z}$		
Signal Type	90 ° ± 4.5 ° square wave pulse		
The maximum output frequency	Max 200 kHz		
Signal level	High: Min 2.5 V		
	Low: max 0.5 V		
Short circuit protection	With		

## Terminal Configuration

Signal	Ub	GND	+C	-C	+D	-D	SET	DIR	A	$\bar{A}$	B	$\bar{B}$	Z	$\bar{Z}$	Shield
Cable ( color )	Brown	White	Green	Yellow	Gray	Pink	Black	Red	Blue	Purple	Gray/ Pink	Red/ Blue	White/ Green	Brown/ Green	
8-pin M12 connector pin holder (pin number)	2	1	3	4	5	6	7	8	-	-	-	-	-	-	
12-pin M23 connector pin holder (pin number)	2	1	3	4	5	6	7	8	9	10	11	12	-	-	
16-pin M23 connector pin holder (pin number)	11	12	2	1	3	4	9	8	5	6	7	10	13	14	

## Top view of the socket

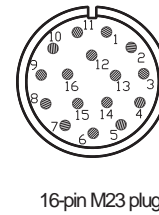
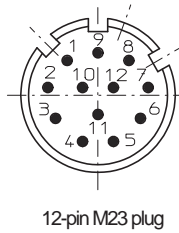
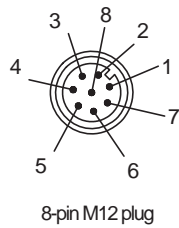

### LED status indicator

The encoder optional two LED status indicators

Green: The encoder power indicator ;  
When the encoder power, the green indicator light ;  
When you press the reset button, the green light is off, re-lit until you release the reset button.

Red: diagnostic lights; when the following conditions, the red light  
Measurement system severely degraded (encoder still work)  
EEPROM failure or malfunction  
Opto-ASIC optical system failure

### Reset button

Optional encoder reset button, and SET same function:

Operation: When you need to set the encoder output current value is 0, while pressing the reset button A and B, and the holding time more than one second, the encoder current value becomes zero ;

## Mounting Accessories

Shaft encoder mounting accessories: Aluminum coupling shaft diameter of 6mm

F30-3025-0606

Spring steel coupling shaft diameter of 10mm

F20-5025-1010

For more accessories please refer to the attached section

## Axis - Dimensions

Clamping flange,  $\varnothing 10\text{mm}$  shaft diameter

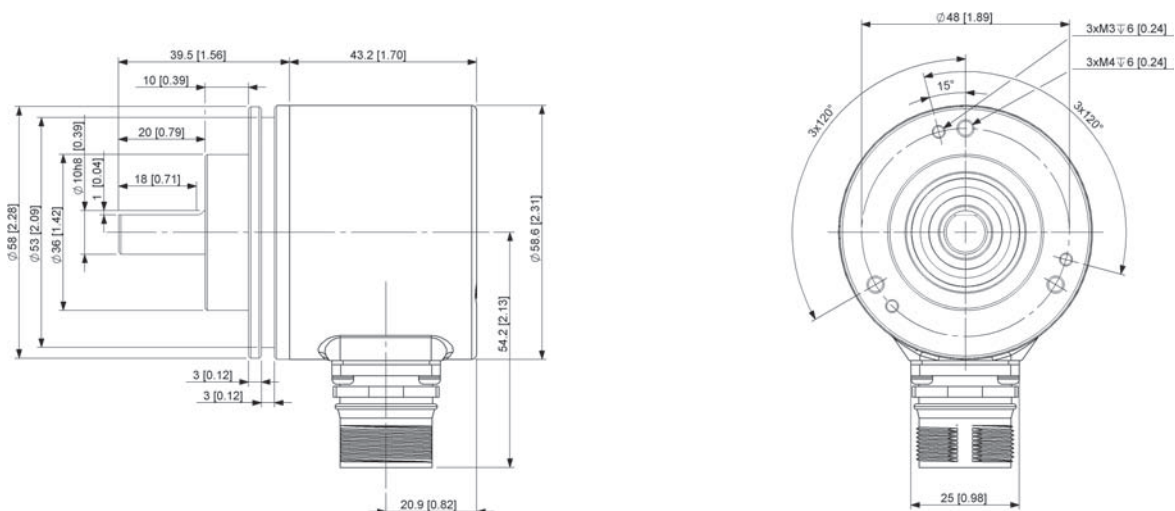

Synchro flange Ø6mm shaft diameter

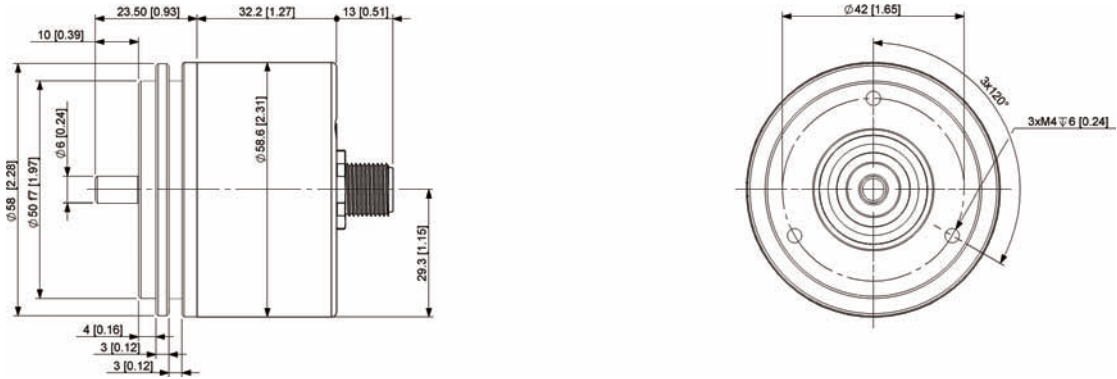

## Sleeve type - Dimensions

Blind hollow shaft, connection

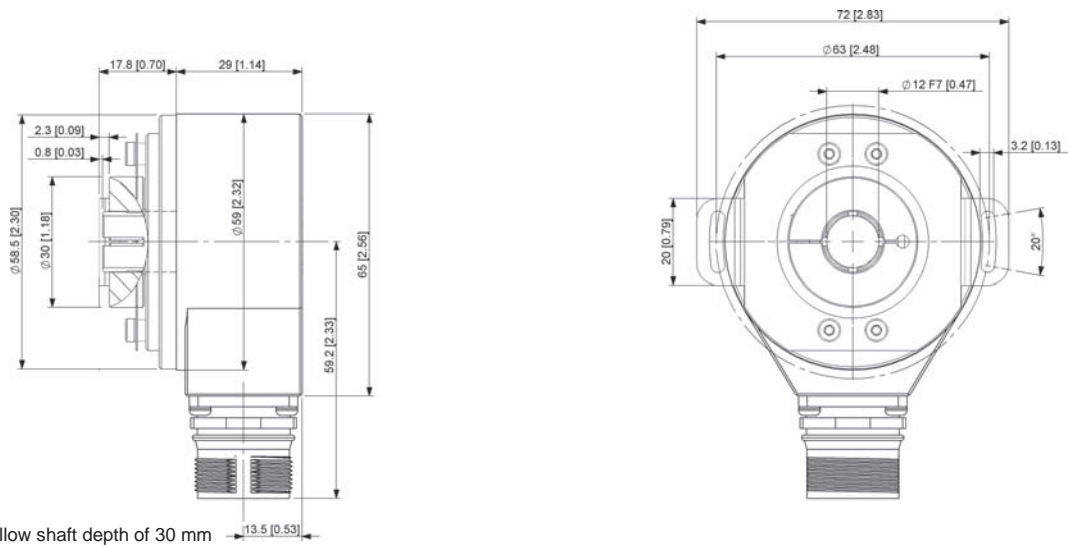

Blind hollow shaft depth of 30 mm

## Order code- shaft version

HB1 - 5 8 A - X X X - X X X X - X  
**Series - Standard**    A    B    C    D    E    F    G

### A Code

B = binary code  
 G = Gray code

### C Flange Type

- 1 = Clamping flange , IP65
- 2 = Clamping flange , IP67
- 3 = Synchro flange , IP65
- 4 = Synchro flange , IP67

### E Output /Power supply

- 1 = SSI output / 5 ... 30 VDC power supply
- 3 = SSI output / 5 ... 30 VDC power supply  
With TTL 1024 ppr
- 4 = SSI output / 5 ... 30 VDC power supply  
With HTL 1024 ppr
- 5 = SSI output / 5 ... 30 VDC power supply  
With TTL 2048 ppr
- 6 = SSI output / 5 ... 30 VDC power supply  
With HTL 2048 ppr

### F Connection

- 1 = Axial 1 m cable
- 2 = Radial 1 m cable
- 3 = Axial M12 connector
- 5 = Radial M12 connector
- 6 = Axial M23 12-pin connector
- 7 = Radial M23 12-pin connector
- 8 = Axial M23 16-pin connector
- 9 = Radial M23 16-pin connector

### B singleturn resolution

- 12 = 12 bit
- 13 = 13 bit
- 16 = 16 bit

### D Shaft diameter

- 2 =  $\varnothing$  6 x 10 mm
- 5 =  $\varnothing$  10 x 20 mm

### G function

- BLANK= No additional features
- S= With reset button and LED

## Order code- Hollow shaft

HB1 - 5 8 C - X X X - X X X X - X  
**Series - Standard**    A    B    C    D    E    F    G

### A Code

B = Binary  
 G = Gray

### C Flange Type

- 8 = Flying wing with fixed connectors , IP65

### E Output /Power supply

- 1 = SSI output / 5 ... 30 VDC power supply
- 3 = SSI output / 5 ... 30 VDC power supply  
WithTTL 1024 ppr
- 4 = SSI output / 5 ... 30 VDC power supply  
WithHTL 1024 ppr
- 5 = SSI output / 5 ... 30 VDC power supply  
WithTTL 2048 ppr
- 6 = SSI output / 5 ... 30 VDC power supply  
WithHTL 2048 ppr

### F Connection

- 2 = Radial 1 m cable
- 5 = Radial M12 connector
- 7 = Radial M23 12-pin connector
- 9 = Radial M23 16-pin connector

### B singleturn resolution

- 12 = 12 bit
- 13 = 13 bit
- 16 = 16 bit

### D Shaft diameter

- 4 =  $\varnothing$  8mm
- 5 =  $\varnothing$  10mm
- 6 =  $\varnothing$  12mm
- 7 =  $\varnothing$  14mm Blind hollow shaft
- 8 =  $\varnothing$  15mm Blind hollow shaft

### G function

- BLANK= No additional features
- S = With reset button and LED

## Absolute lap Profibus-DP HB4-58



- Shape 58mm, compact, rugged, suitable for industrial field and outdoor use
- Wide operating temperature range -40 ° C ... + 85 °
- Profibus-DP interface, using the latest fieldbus protocol
- Optical sensor technology, resolution up to 16bits
- Protection class up to IP67
- Has a direct outlet, M12 and other connections to choose from



Mechanical characteristics		Profibus-DP interface parameters	
Max. speed	12000 min <sup>-1</sup>	Interface Type	Profibus-DP interface
Starting torque	0.03 N.m MAX	Output circuit	RS-485 interface, using opto-electrical isolation
Moment of inertia	≤ 30 gcm <sup>2</sup>	Baud rate	≤ 12 Mbit / s (can be set by software)
Shaft load capacity -radial	110 N	Interface cycle	> 1 ms
Shaft load capacity -axial	40 N	Code	Binary
Protection acc.to EN 60 529	Optional IP65 IP67	singleturn resolution	Max.16 bits
Operation temperature	-40 - 85°C	-	-
Materials	Shaft: Stainless steel; flange, Housing: Aluminum	Profile	In line with standard Profibus-DP DPV0, DPV1 and DPV2 Class 2 ( EN50170+EN50254 )
Weight	About 0.550 kg		
shock resistance EN 60068-2-29	1000m/s <sup>2</sup> , 6ms		
vibration resistance EN 60068-2-27	100m/s <sup>2</sup> , 10-2000Hz	Node address	1 ... 99, 32 default address (via rotary switch setting)
Mechanical life Fa/Fr	40/60 40/80 40/110	terminal resistance	Built-in termination resistors (via DIP switch setting)
	247 110 42	Electrical life	> 10 <sup>5</sup> h
<b>Electrical parameters</b>		Profibus-DP fieldbus standard interface protocols in line, in line with DPV0, DPV1	
Power supply	10 ... 30 VDC	And DPV2 Class 2 (EN50170 + EN50254) functional requirements	
power consumption	Typical 100 mA, max 230 mA	The following parameters are programmable Review :	
Drive circuit	RS 485	-Counting direction	
Start time	< 250 ms	-Singleturn resolution	
Output short circuit protection	With	-Total Resolution	
Reverse polarity connection protection	With	-Current output value	
UL-approval	File 251481	-Communication rate	
CE compliant	EN 61000-6-4; EN61000-6-2	-Synchronous mode	
RoHs compliant	Follow 2002/95 / EG EG- rules		

### LED status indicator

The encoder has two LED status indicators are red and green, with seven kinds of combinations of state, represent the seven kinds of state of the encoder. See detailed operating manual.

## Terminal Configuration

### Terminal Coupler

Signal	BUS IN				BUS OUT			
	B	A	0 V	+ V	B	A	0 V	+ V
Terminal No.	1	2	3	4	5	6	7	8

### M12 connector

#### Bus in( Headers )

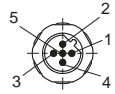

Signal	-	BUS-A	-	BUS-B	-
Pin No.	1	2	3	4	5

#### Bus out( Hole Block )

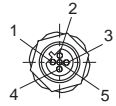

Signal	-	BUS-A	-	BUS-B	-
Pin No.	1	2	3	4	5

#### Power (headers)

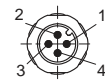

Signal	+V	--	-V	--
Pin No.	1	2	3	4

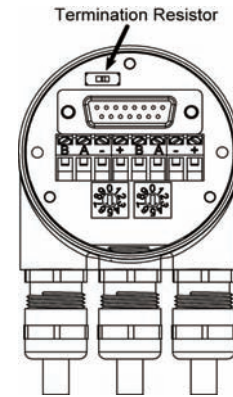

## Mounting Accessories

Cable connector: M12 Self-assembly plug (Bus into)

Self-assembled M12 plug (Bus out)

Shaft encoder mounting accessories: Aluminum coupling shaft diameter of 6mm

Spring steel coupling shaft diameter of 10mm

For more accessories please refer to the attached section

EK5228-0 / 9

EZ5228-0 / 9

F30-3025-0606

F20-5025-1010

## Axis - Dimensions

Clamping flange, Ø10mm Shaft diameter

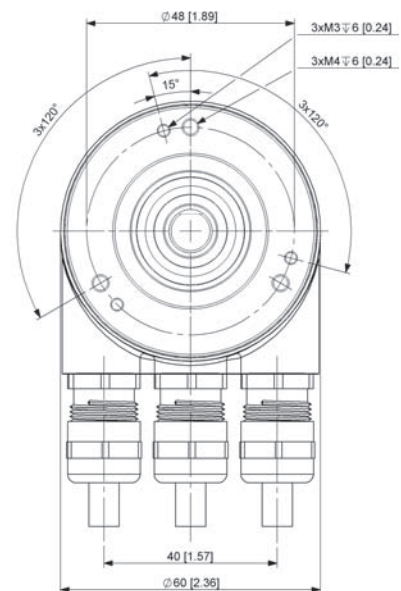
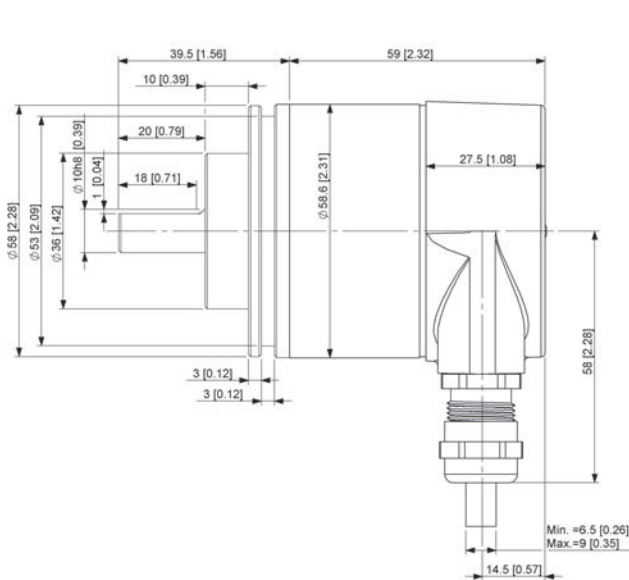

Synchro flange, Ø10mm shaft diameter

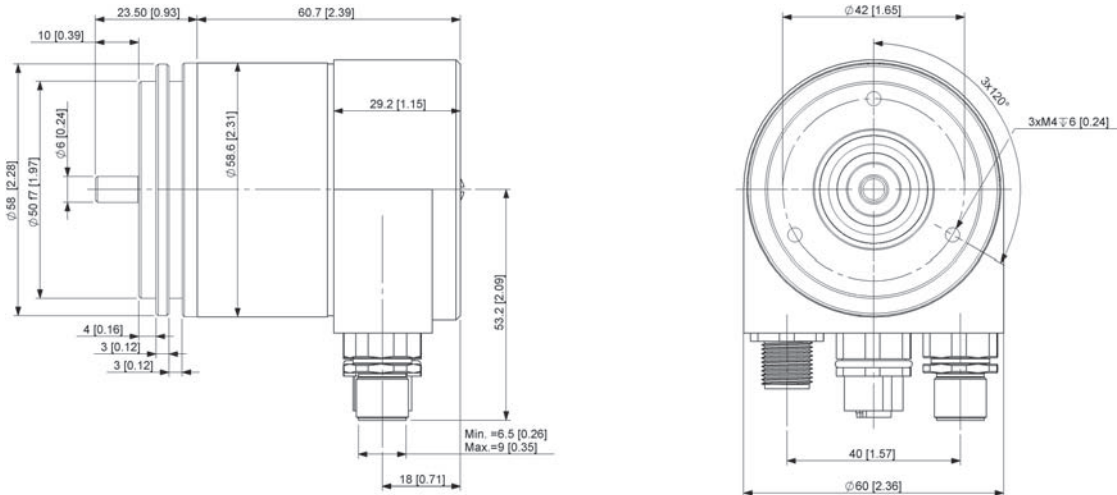

Sleeve type - Dimensions

Blind hollow shaft

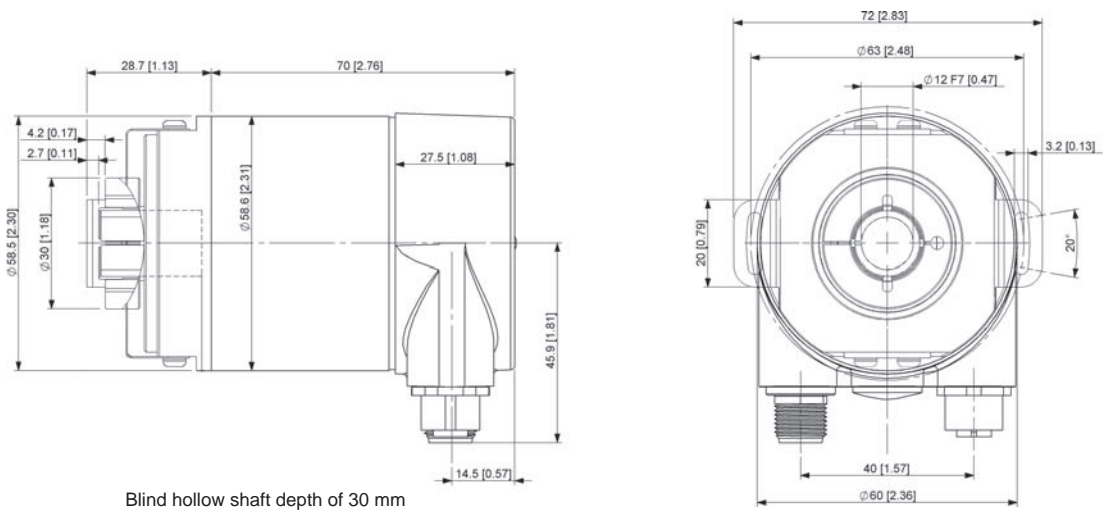



# Absolute Encoders-Singleturn

## Order code- shaft version

HB4 - 5 8 A - X X X - X X X X - X  
**Series - Standard**    A    B            C    D    E    F    G

### A Code

B = Binary

### C Flange Type

1 = Clamping flange , IP65  
 2 = Clamping flange , IP67  
 3 = Synchro flange , IP65  
 4 = Synchro flange , IP67

### E output/Power supply

3 = Profibus-DP output / 10 ... 30 VDC  
 power supply

### G function

BLANK = No additional features  
 S = with reset button

### B Singleturn resolution

12 = 12 bit  
 13 = 13 bit  
 16 = 16 bit

### D Shaft diameter

2 =  $\varnothing$  6x10mm  
 5 =  $\varnothing$  10x20mm

### F Connection

1 = with removable terminal coupling junction box,  
 Radial 3x cable nut  
 2 = with removable terminal coupling junction box,  
 Radial connector 3xM12

## Order code- Hollow shaft

HB4 - 5 8 C - X X X - X X X X - X  
**Series - Standard**    A    B            C    D    E    F    G

### A Code

B = Binary

### C Flange Type

8 = Flying wing with fixed  
 connectors , IP65

### E output/Power supply

3 = Profibus-DP output / 10 ... 30 VDC  
 power supply

### G function

BLANK = No additional features  
 S = with reset button

### B Singleturn resolution

12 = 12 bit  
 13 = 13 bit  
 16 = 16 bit

### D Shaft diameter

4 =  $\varnothing$  8 mm  
 5 =  $\varnothing$  10 mm  
 6 =  $\varnothing$  12 mm  
 7 =  $\varnothing$  14 mm  
 8 =  $\varnothing$  15 mm

### F Connection

1 = with removable terminal coupling junction box,  
 Radial 3x cable nut  
 2 = with removable terminal coupling junction box,  
 Radial connector 3xM12

## Absolute lap DeviceNET HB4-58



- Shape 58mm solid and reliable, suitable for applications in engineering vehicles and other industries
- Wide operating temperature range -40 °C ... + 85 °
- DeviceNET interface, using the latest fieldbus protocol
- Optical sensor technology, resolution up to 16bits
- High degree of protection up to IP67
- Has a direct outlet, M12 and other connections to choose from



Mechanical characteristics				DeviceNET interface parameters	
Max.speed	12000 min <sup>-1</sup>			Interface Type	DeviceNET interface
Starting torque	0.03 N.m MAX			Output circuit	Data bus interface, using electrically isolated optocoupler
Moment of inertia	≤ 30 gcm <sup>2</sup>			Baud rate	≤ 500 Kbit / s (can be set by software)
Shaft load capacity -radial	110 N			Code	Binary
Shaft load capacity -axial	40 N			singleturn resolution	Max.16 bits
Protection acc.to EN 60 529	Optional IP65 IP67			--	--
Operation temperature	-40 - 85°C			Profile	DeviceNET interface complies ISO/DIS 11898
Materials	Shaft: Stainless steel; flange, Housing: Aluminum			Node address	1 ... 64 (Via rotary switch setting)
Weight	About 0.325 kg			Terminal resistance	Built-in termination resistors (via DIP switch setting)
shock resistance EN 60068-2-29	1000m/s <sup>2</sup> , 6ms			Electrical life	> 10 <sup>5</sup> h
vibration resistance EN 60068-2-27	100m/s <sup>2</sup> , 10-2000Hz				
Mechanical life Fa/Fr	40/60 262	40/80 110	40/110 42		
GE parameters				DeviceNET interface complies with ISO / DIS 11898	
Power supply	10 ... 30 VDC			The following parameters are programmable modification	
power consumption	Typical 100 mA, max 230 mA			-Counting direction	
Drive circuit	RS 485			-Lap Resolution	
Start time	< 250 ms			-Total Resolution	
Output short circuit protection	With			-Baud rate and node address	
Reverse polarity protection of the power supply	With			-Prefabricated value	
UL-approval	File 251481			-Terminating resistor	
CE compliant	EN 61000-6-4; EN61000-6-2				

### Terminant assignment

Connection to the junction box and 2 x M 12 connector when

Description	IN					OUT		
	+V	0 V	CAN(GND)	CAN(Low)	CAN(High)	CAN(GND)	CAN(Low)	CAN(High)
Signal	+V	0 V	CAN(GND)	CAN(Low)	CAN(High)	CAN(GND)	CAN(Low)	CAN(High)
Junction Box Wiring	+	--	G	L	H	G	L	H
2 X M12 connector*	2	3	1	5	4	1	5	4

\* 2 X M12 connector to connect the way, the bus entrance to the needle seat, bus seat outlet holes, the power supply section that connection 2,3 needles with an internal short circuit in the encoder.

# Absolute Encoders-Singleturn

When the connection is the connector

Description	IN				
	+V	0 V	CAN(GND)	CAN(Low)	CAN(High)
M12 connector	2	3	1	5	4

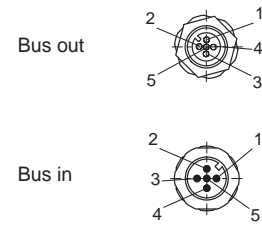

## Mounting Accessories

Cable connector: M12 Self-assembly plug (hole end)

Self-assembled M12 connector (pin end)

Shaft encoder mounting accessories: Aluminum coupling shaft diameter of 6mm

Spring steel coupling shaft diameter of 10mm

For more accessories please refer to the attached section

EK5212-0 / 9

EZ5212-0 / 9

F30-3025-0606

F20-5025-1010

## Axis - Dimensions

Clamping flange,  $\varnothing 10\text{mm}$  Shaft diameter

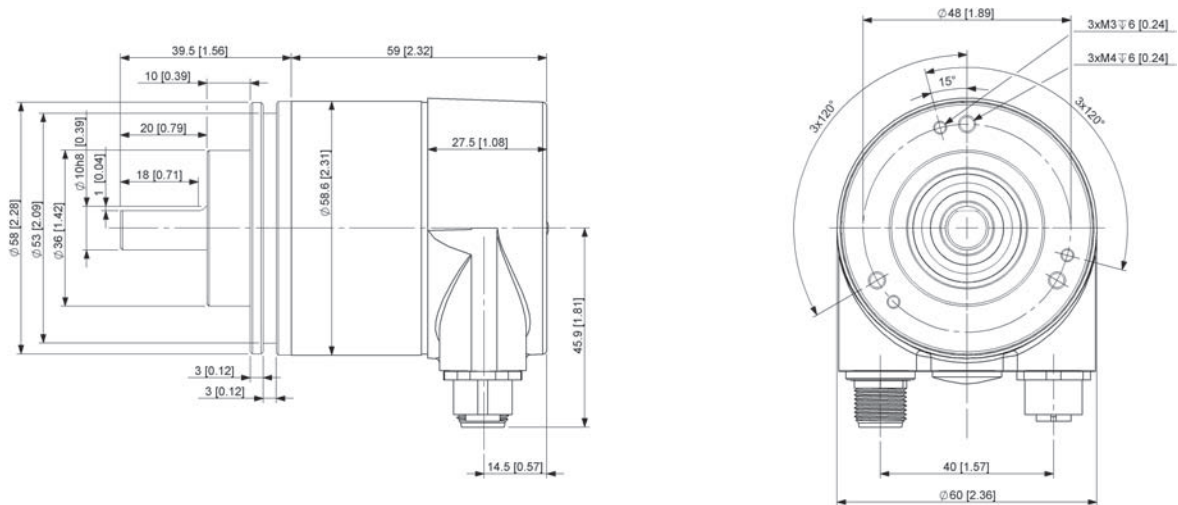

Synchro flange , Ø10mm Shaft diameter

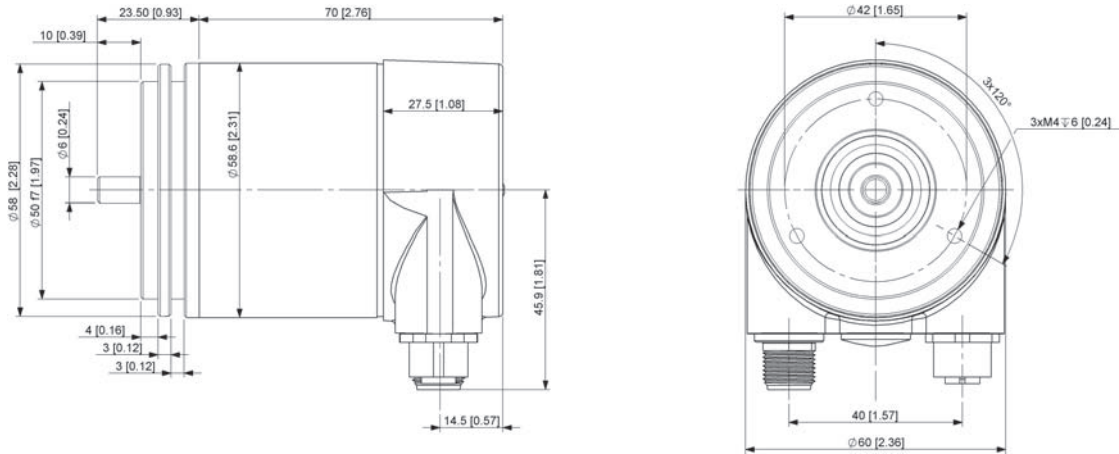

## Sleeve type - Dimensions

Blind hollow shaft, connection

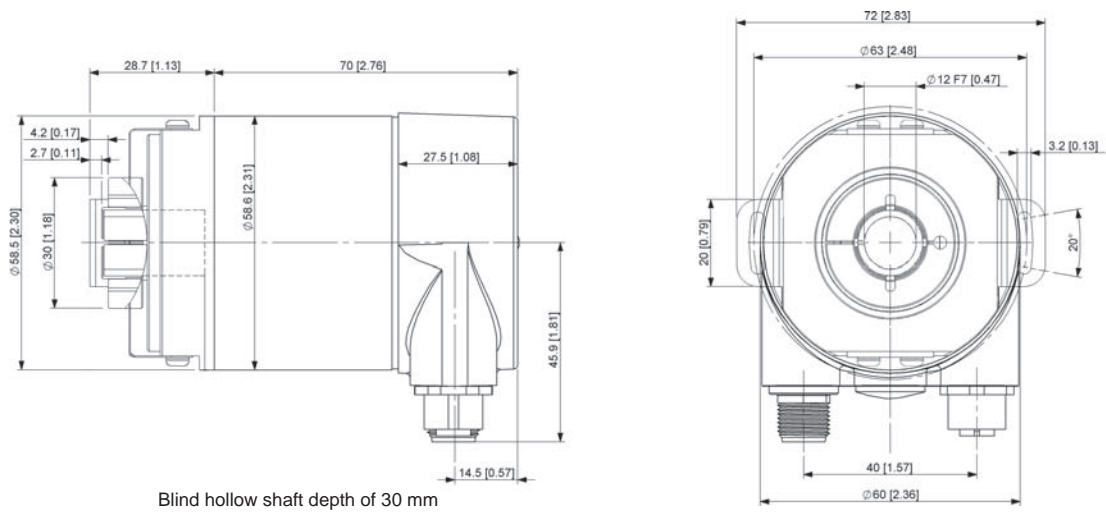

Blind hollow shaft depth of 30 mm

# Absolute Encoders-Singleturn

## Order code- shaft version

HB4 - 5 8 A - X X X - X X X X - X  
**Series - Standard**    A    B        C    D    E    F    G

### A Code

B = Binary

### C Flange Type

1 = Clamping flange , IP65  
 2 = Clamping flange , IP67  
 3 = Synchro flange , IP65  
 4 = Synchro flange , IP67

### E output / supply voltage

6 = DeviceNET output / 10 ... 30 VDC  
 power supply

### G function

BLANK = No additional features

### B Singleturn resolution

12 = 12 bit  
 13 = 13 bit  
 16 = 16 bit

### D Shaft diameter

2 =  $\varnothing$  6x10mm  
 5 =  $\varnothing$  10x20mm  
 6 =  $\varnothing$  12x20mm

### F Connection

1 = with removable terminal coupling junction box,  
 Radial 2x cable nut  
 2 = with removable terminal coupling junction box,  
 Radial connector 2xM12  
 5 = radial connector 1XM12

## Order code- Hollow shaft

HB4 - 5 8 C - X X X - X X X X - X  
**Series - Standard**    A    B        C    D    E    F    G

### A Code

B = Binary

### C Flange Type

8 = Flying wing with fixed  
 connectors , IP65  
 9 = Flying wing with fixed  
 connectors , IP67

### E output / supply voltage

6 = DeviceNET output / 10 ... 30 VDC  
 power supply

### G function

BLANK = No additional features

### B Singleturn resolution

12 = 12 bit  
 13 = 13 bit  
 16 = 16 bit

### D Shaft diameter

2 =  $\varnothing$  6 mm  
 4 =  $\varnothing$  8 mm  
 5 =  $\varnothing$  10 mm  
 6 =  $\varnothing$  12 mm  
 7 =  $\varnothing$  14 mm  
 8 =  $\varnothing$  15 mm

### F Connection

1 = with removable terminal coupling junction box,  
 Radial 2x cable nut  
 2 = with removable terminal coupling junction box,  
 Radial connector 2xM12  
 5 = radial connector 1XM12

## Absolute lap CANopen / CANlift HB4-58



- Shape 58mm solid and reliable, suitable for applications in engineering vehicles and other industries
- Wide operating temperature range -40 ° C ... + 85 °
- CANopen / CANlift interface, using the latest fieldbus protocol
- Optical sensor technology, resolution up to 16bits
- High degree of protection can be directly used for outdoor
- Has a direct outlet, M12 and other connections to choose from



Mechanical characteristics			CANopen / CANlift interface parameters	
Max.speed	12000 min <sup>-1</sup>		Interface Type	CANopen / CANlift interface
Starting torque	0.03 N.m MAX		Output circuit	Data bus interface, using electrically isolated optocoupler
Moment of inertia	≤ 30 gcm <sup>2</sup>		Baud rate	≤ 1 Mbit / s (can be set by software)
Shaft load capacity -radial	110 N		Transmission cycle	> 1ms
Shaft load capacity -axial	40 N		Code	Binary
Protection acc.to EN 60 529	Optional IP65 IP67		Singleturn resolution	Max.16 bits
Operation temperature	-40 - 85°C		-	-
Materials	Shaft : Stainless steel ; Flange, housings : aluminium alloy		Profile	CANopen DS406 accord CANlift comply DS417
Weight	About 0.325 kg		Node address	1 ... 127, the default address 32 (Via rotary switch setting)
shock resistance EN 60068-2-29	1000m/s <sup>2</sup> , 6ms		terminal resistance	Built-in (via DIP switch or software)
vibration resistance EN 60068-2-27	100m/s <sup>2</sup> , 10-2000Hz		Electrical life	> 10 <sup>5</sup> h
Mechanical life Fa/Fr	40/60    40/80    40/110 262       110       42			
GE parameters			CANopen interface protocol accord DS406	
Power supply	10 ... 30 VDC		CANlift interface protocol accord DS417	
power consumption	Typical 100 mA, max 230 mA		The following parameters are programmable modification	
Drive circuit	RS 485		-Counting direction	
Start time	< 250 ms		-Resolution	
Output short circuit protection	With		-Prefabricated value, baud rate and node address	
Reverse polarity connection protection	With		-Two limit points and eight cam	
UL-approval	File 251481		-Terminal resistance	
CE compliant	EN 61000-6-4; EN61000-6-2		-Transmit mode: rotation mode, periodic transmission mode, synchronous mode	

### Terminant assignment

Connection for junction boxes and connectors when 2x M12

Description	IN					OUT		
	+V	0 V	CAN(GND)	CAN(Low)	CAN(High)	CAN(GND)	CAN(Low)	CAN(High)
Junction Box Wiring	+	--	G	L	H	G	L	H
2 X M12 connector*	2	3	1	5	4	1	5	4

\* 2 X M12 connector to connect the way, the bus entrance to the needle seat, bus seat outlet holes, the power supply section that connection 2,3 needles with an internal short circuit in the encoder.

# Absolute Encoders-Singleturn

Connection to the cable outlet and connectors

Description	IN				
	+V	0 V	CAN(GND)	CAN(Low)	CAN(High)
M12 connector	2	3	1	5	4
Cable color	White	Brown	Green	Pink	Yellow

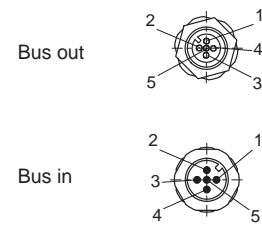

## Mounting Accessories

Cable connector: M12 Self-assembly plug (hole end)

Self-assembled M12 connector (pin end)

Shaft encoder mounting accessories: aluminum coupling shaft diameter of 6mm

Spring steel coupling shaft diameter of 10mm

For more accessories please refer to the attached section

EK5212-0 / 9

EZ5212-0 / 9

F30-3025-0606

F20-5025-1010

## Axis - Dimensions

Clamping flange, Ø10mm shaft diameter

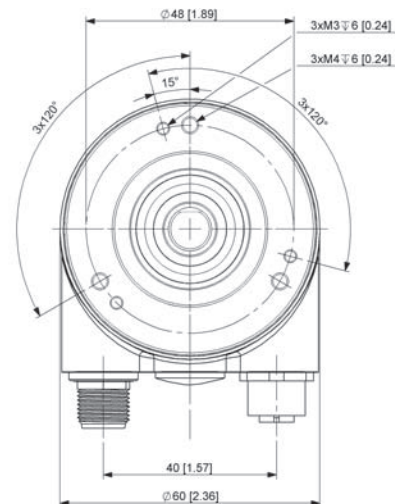
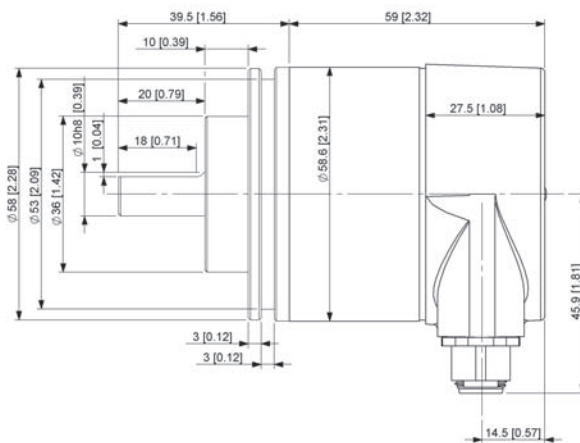

Clamping flange, Ø10mm shaft diameter

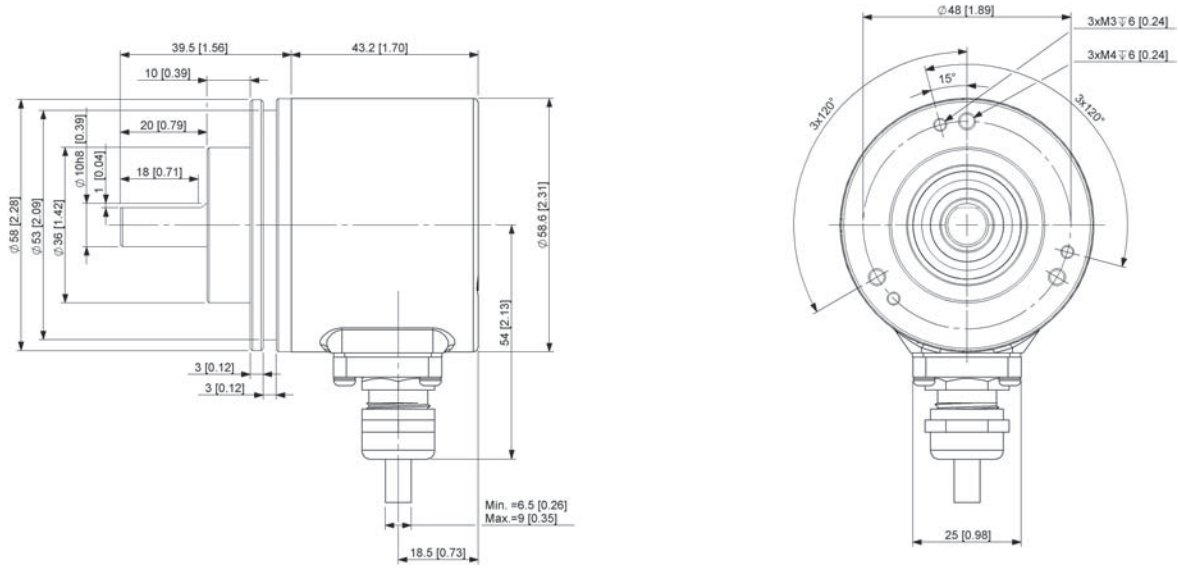

Synchro flange Ø 6mm shaft, connectors

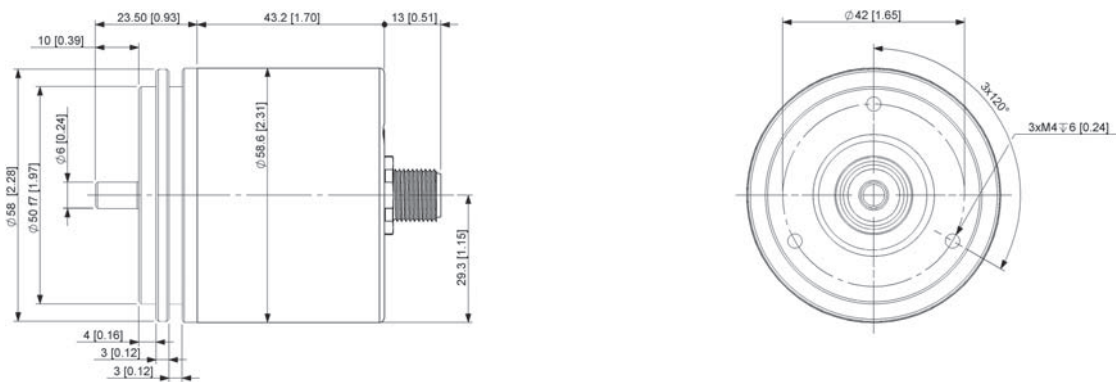

Synchro flange Ø 6mm shaft, qualifying

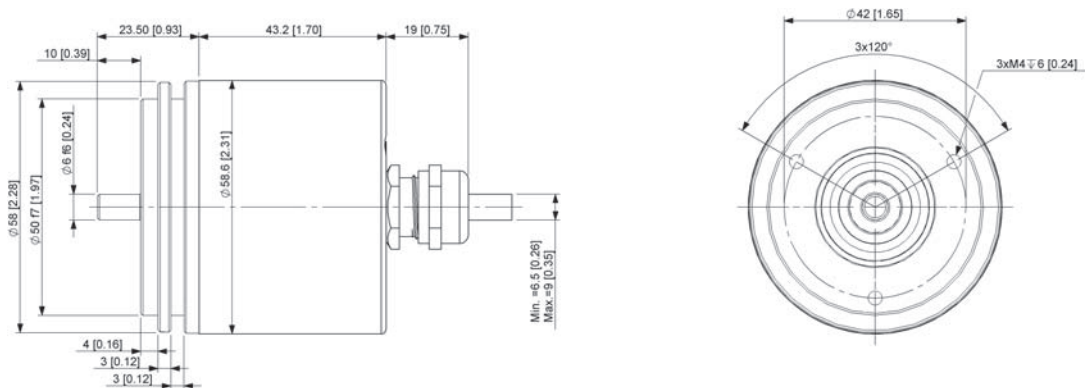



## Sleeve type - Dimensions

Blind hollow shaft

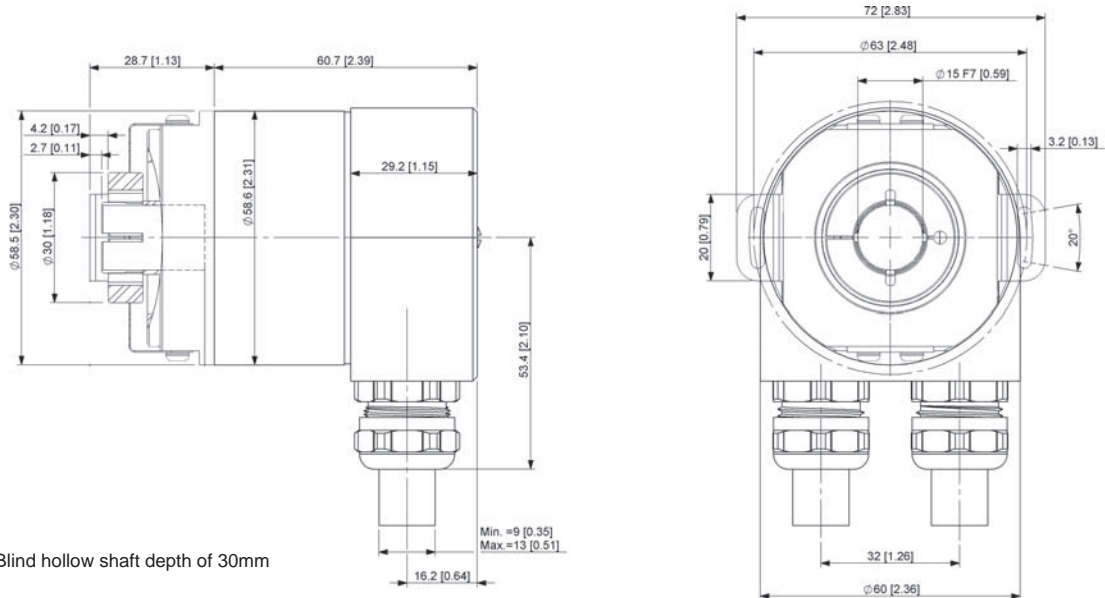

Blind hollow shaft depth of 30mm

### Order code- shaft version

HB4 - 5 8 A - X X X - X X X X  
**Series - Standard**    A    B            C    D    E    F

#### A Code

B = Binary

#### B Singleturn resolution

12 = 12 bit  
 13 = 13 bit  
 16 = 16 bit

#### C Flange Type

1 = Clamping flange , IP65  
 2 = Clamping flange , IP67  
 3 = Synchro flange , IP65  
 4 = Synchro flange , IP67

#### D Shaft diameter

2 = ø 6x10mm  
 5 = ø 10x20mm  
 6 = ø 12x20mm

#### E output / supply voltage

4 = CANopen / 10 ... 30 VDC power supply  
 5 = CANlift / 10 ... 30 VDC power supply

#### F Connection

1 = with removable terminal coupling junction box,  
 Radial 2x cable nut  
 2 = with removable terminal coupling junction box,  
 Radial connector 2xM12  
 3 = axial connector 1XM12  
 5 = radial connector 1XM12  
 6 = radial 1 m cable

### Order code- Hollow shaft

HB4 - 5 8 C - X X X - X X X X  
**Series - Standard**    A    B            C    D    E    F

#### A Code

B = Binary

#### B Singleturn resolution

12 = 12 bit  
 13 = 13 bit  
 16 = 16 bit

#### C Flange Type

8 = Flying wing with fixed  
 connectors , IP65  
 9 = Flying wing with fixed  
 connectors , IP67

#### D Shaft diameter

2 = ø 6 mm  
 4 = ø 8 mm  
 5 = ø 10 mm  
 6 = ø 12 mm  
 7 = ø 14 mm  
 8 = ø 15 mm

#### E output / supply voltage

4 = CANopen / 10 ... 30 VDC power supply  
 5 = CANlift / 10 ... 30 VDC power supply

#### F Connection

1 = with removable terminal coupling junction box,  
 Radial 2x cable nut  
 2 = with removable terminal coupling junction box,  
 Radial connector 2xM12  
 5 = radial connector 1XM12  
 6 = radial 1 m cable

## Absolute multi-turn SSI HC1-58



- Shape 58mm, standard industrial design, may be accompanied by incremental signal output
- Wide operating temperature range -40 °C ... + 85 °
- SSI synchronous serial interface output can be preset initial value, counting direction can be changed
- Lap up to 16 bits resolution
- Multiturn mechanical gear system, laps up to 14bits
- With a cable outlet, M12, M23 multiple connectivity options to choose from



Mechanical characteristics		SSI interface parameters	
Max.speed	12000 min <sup>-1</sup>	Power supply	5-30 VDC
Starting torque	0.03 N.m MAX	power consumption	50 mA
Moment of inertia	≤ 30 gcm <sup>2</sup>	Interface Type	SSI Synchronous Serial Interface
Shaft load capacity -radial	110 N	Drive circuit	RS 422
Shaft load capacity -axial	40 N	Input clock frequency	100 kHz ... 2 MHz
Protection acc.to EN 60 529	Optional IP65 IP67	Monostable time	> 25µs
Operation temperature	-40 - 85°C	Start time	< 250 ms
Materials	Shaft: Stainless steel	Code	Gray/Binary
	Housing: Aluminum	Singleturn resolution	Max 16 bits
	Flange: Aluminum	Laps	Max 14 bits
Weight	About 0.285 kg	Function	Can be prefabricated (1); to change the counting direction (2)
Shock resistance EN 60068-2-29	1000m/s <sup>2</sup> , 6ms	Output short circuit protection	Have
vibration resistance EN 60068-2-27	100m/s <sup>2</sup> , 10-2000Hz	Reverse polarity protection of the power supply	Have
Mechanical life Fa/Fr	40/60 40/80 40/110	Approval	File 251481
	247 104 40	Accord	EN 61000-6-4:2007-09 EN61000-6-2:2005
Explosion levels	-	( 1 ) can be set by pre-encoder function initial position, when the SET is shorted to the power supply line, longer than 1 second, the encoder will encode the current value is 0; corresponding time 100ms; input impedance 110kΩ	
<b>Additional incremental output (A / B / Z)</b>		( 2 ) Counting direction can be changed by the direction of the encoder function	
Output	TTL/HTL	When the DIR and power lines suspended or negative short-circuited, the encoder shaft by CW direction of rotation, the data output is increased; When the DIR line with the positive supply shorted by CCW rotation encoder, the data output is increased;	
Resolution	1024,2048,4096		
Output channels	A, $\bar{A}$ ; B, $\bar{B}$ ; Z, $\bar{Z}$		
Signal Type	90 ° ± 4.5 ° square wave pulse		
The maximum output frequency	Max 200 kHz		
Signal level	High: Min 2.5 V		
	Low: max 0.5 V		
Short circuit protection	With		

### Terminanl assignment

Signal	Ub	GND	+C	-C	+D	-D	SET	DIR	A	$\bar{A}$	B	$\bar{B}$	Z	$\bar{Z}$	Shield
Cable ( color )	Brown	White	Green	Yellow	Grey	Pink	Black	Red	Blue	Purple	Grey/ Pink	Red/ Blue	White/ Green	Brown/ Green	
8-pin M12 connector pin holder (pin number)	2	1	3	4	5	6	7	8	-	-	-	-	-	-	
12-pin M23 connector pin holder (pin number)	2	1	3	4	5	6	7	8	9	10	11	12	-	-	
16-pin M23 connector pin holder (pin number)	11	12	2	1	3	4	9	8	5	6	7	10	13	14	

## Top view of the socket

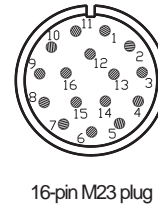
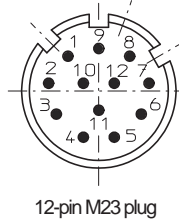
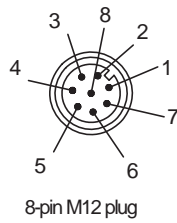

### LED status indicator

The encoder optional two LED status indicators

**Green:** The encoder power indicator;  
When the encoder power, the green indicator light;  
When you press the reset button, the green light is off, re-lit until you release the reset button.

**Red:** diagnostic lights; when the following conditions, the red light  
Measurement system severely degraded (encoder still work)  
EEPROM failure or malfunction  
Opto-ASIC optical system failure

### Reset button

Optional encoder reset button, and SET same function:

**Operation:** When you need to set the encoder output current value is 0, press  
Reset button A and B, retention time exceeds 1 second encoder current value becomes zero ;

## Mounting Accessories

Shaft encoder mounting accessories: aluminum coupling shaft diameter of 6mm

F30-3025-0606

Spring steel coupling shaft diameter of 10mm

F20-5025-1010

For more accessories please refer to the attached section

## Axis - Dimensions

Clamping flange, Ø10mm Shaft diameter

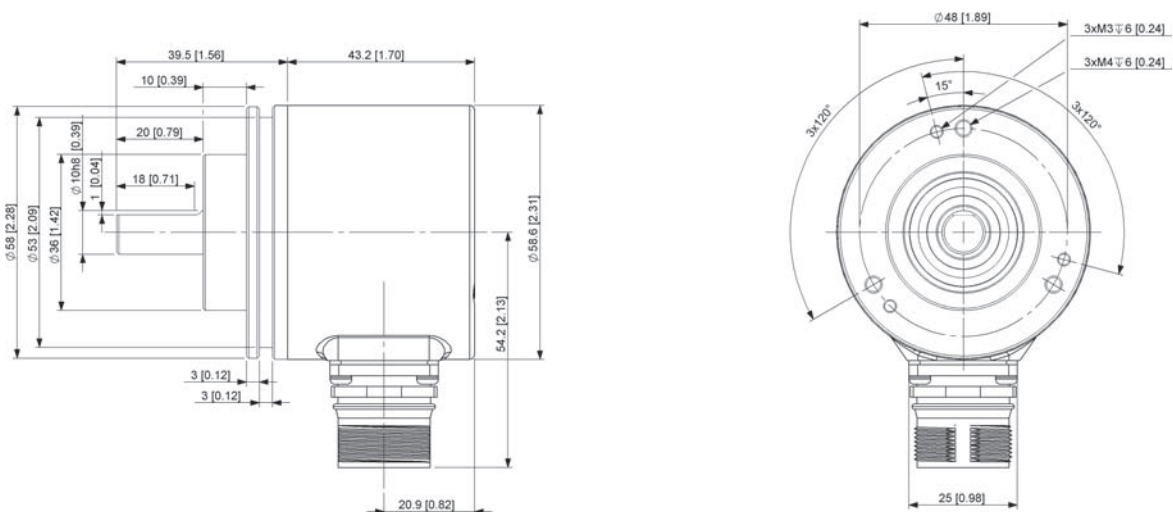

Synchro flange, Ø6mm shaft diameter

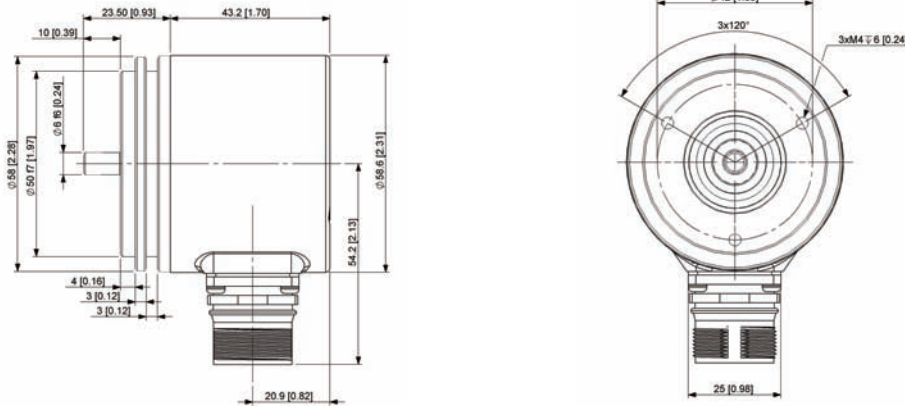

## Sleeve type - Dimensions

Flying wing fixed connectors

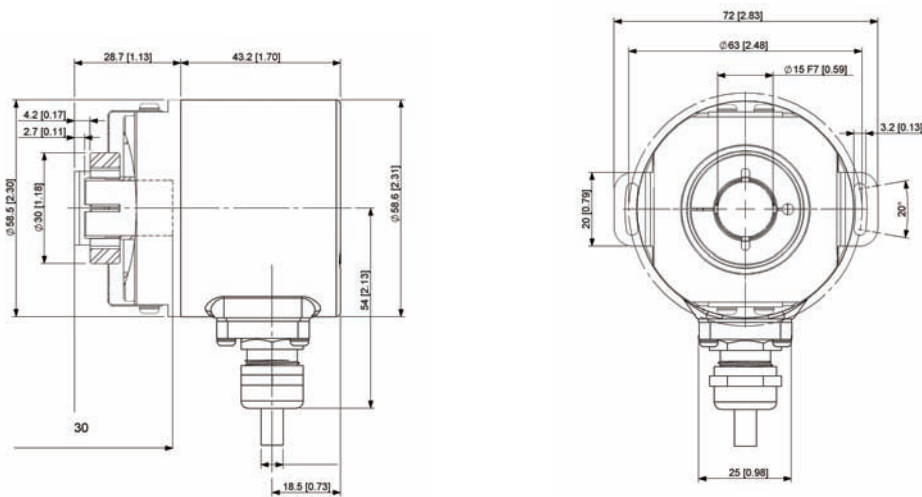

## Order code- shaft version

HC1 - 5 8 A - X X X X X - X X X X - X  
**Series - Standard**    A    B    C    D    E    F    G    H

### A Code

B = Binary  
 G = Gray

### B Singleturn resolution

12 = 12 bit  
 13 = 13 bit  
 16 = 16 bit

### C laps

12 = 12 bit  
 13 = 13 bit  
 14 = 14 bit

### D Flange Type

1 = Clamping flange , IP65  
 2 = Clamping flange , IP67  
 3 = Synchro flange , IP65  
 4 = Synchro flange , IP67

### E Shaft diameter

2 = ø 6 x 10 mm  
 5 = ø 10 x 20 mm

### F output / Power supply

1 = SSI output / 5 ... 30 VDC power supply  
 3 = SSI output / 5 ... 30 VDC power supply  
     With TTL 1024 ppr  
 4 = SSI output / 5 ... 30 VDC power supply  
     With HTL 1024 ppr  
 5 = SSI output / 5 ... 30 VDC power supply  
     With TTL 2048 ppr  
 6 = SSI output / 5 ... 30 VDC power supply  
     With HTL 2048 ppr

### G Connection

1 = Axial 1 m cable  
 2 = Radial 1 m cable  
 3 = Axial M12 connector  
 5 = Radial M12 connector  
 6 = Axial M23 12-pin connector  
 7 = Radial M23 12-pin connector  
 8 = Axial M23 16-pin connector  
 9 = Radial M23 16-pin connector

### H function

BLANK = No additional features  
 S = with reset button LED

## Order code- Hollow shaft

HC1 - 5 8 C - X X X X X - X X X X - X  
**Series - Standard**    A    B    C    D    E    F    G    H

### A Code

B = Binary  
 G = Gray

### B Singleturn resolution

12 = 12 bit  
 13 = 13 bit  
 16 = 16 bit

### C laps

12 = 12 bit  
 13 = 13 bit  
 14 = 14 bit

### D Flange Type

8 = Flying wing with fixed connectors , IP65

### E Shaft diameter

4 = ø 8 mm  
 5 = ø 10 mm  
 6 = ø 12 mm  
 7 = ø 14 mm Blind hollow shaft  
 8 = ø 15 mm Blind hollow shaft

### F output / Power supply

1 = SSI output / 5 ... 30 VDC power supply  
 3 = SSI output / 5 ... 30 VDC power supply  
     With TTL 1024 ppr  
 4 = SSI output / 5 ... 30 VDC power supply  
     With HTL 1024 ppr  
 5 = SSI output / 5 ... 30 VDC power supply  
     With TTL 2048 ppr  
 6 = SSI output / 5 ... 30 VDC power supply  
     With HTL 2048 ppr

### G Connection

2 = Radial 1 m cable  
 5 = Radial M12 connector  
 7 = Radial M23 12-pin connector  
 9 = Radial M23 16-pin connector

### H function

BLANK = No additional features  
 S = with reset button LED

## Absolute multiturn Profibus-DP HC4-58



- Shape 58mm, compact, rugged, suitable for industrial field
- Wide operating temperature range -40 ° C ... + 85 °
- Profibus-DP interface, using the latest fieldbus protocol
- Optical sensor technology, resolution up to 16bits
- Multiturn mechanical gear system, the number of turns of up to 14 bits
- M12 and other connections to choose



Mechanical characteristics		Profibus-DP interface parameters	
Max.speed	12000 min <sup>-1</sup>	Interface Type	Profibus-DP interface
Starting torque	0.03 N.m MAX	Output circuit	RS-485 interface
Moment of inertia	≤ 30 gcm <sup>2</sup>	Baud rate	≤ 12 Mbit / s (can be set by software)
Shaft load capacity -radial	110 N	Interface cycle	> 1 ms
Shaft load capacity -axial	40 N	Code	Binary
Protection acc.to EN 60 529	Optional IP65 IP67	singleturn resolution	Max.16 bits
Operation temperature	-40 - 85°C	Laps	Max.14 bits
Materials	Shaft: Stainless steel; Flange housings: aluminium alloy	Profile	In line with standard Profibus-DP DPV0、DPV1和DPV2 Class2 ( EN50170+EN50254 )
Weight	About 0.550 kg	Node address	1 ... 99, 32 default address (Via rotary switch setting)
Shock resistanceEN 60068-2-29	1000m/s <sup>2</sup> , 6ms	Termination resistors	via DIP switch setting
Vibration resistance EN 60068-2-27	100m/s <sup>2</sup> , 10-2000Hz	Electrical life	> 10 <sup>5</sup> h
Mechanical life Fa/Fr	40/60    40/80    40/110 247       110       42		
Electrical characteristics			
Power supply	10 ... 30 VDC	Profibus-DP fieldbus standard interface protocols in line, DPV0, DPV1	
power consumption	Typical 100 mA, max 230 mA	And DPV2 Class 2 ( EN50170+EN50254 ) Functional requirements.	
Drive circuit	RS 485	The following parameters are programmable Review :	
Start time	< 250 ms	-Counting direction	
Output short circuit protection	With	-singleturn resolution	
Reverse polarity protection	With	-Total Resolution	
UL-approval	File 251481	-Current output value	
CE compliant	EN 61000-6-4; EN61000-6-2	-Communication rate	
RoHs compliant	Follow the rules to follow EG- 2002/95 / EG	-synchronous mode	

## LED status indicator

The encoder has two LED status indicators are red and green, with seven kinds of combinations of state, represent the seven kinds of state of the encoder. See detailed operating manual.

## Terminal Configuration

### Terminal Coupler

Signal	BUS IN				BUS OUT			
	B	A	0 V	+ V	B	A	0 V	+ V
Terminal No.	1	2	3	4	5	6	7	8

### M12 connector

#### Bus in

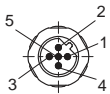

Signal	-	BUS-A	-	BUS-B	-
Pin No.	1	2	3	4	5

#### Bus out

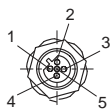

Signal	-	BUS-A	-	BUS-B	-
Pin No.	1	2	3	4	5

#### Power



Signal	+V	--	-V	--
Pin No.	1	2	3	4

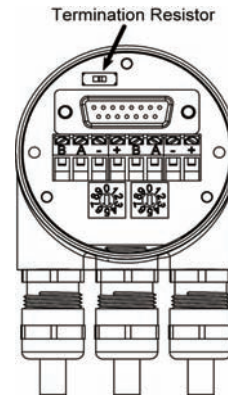

## Mounting Accessories

Cable connector: M12 Self-assembly plug (Bus into)  
Self-assembled M12 plug (Bus out)

Shaft encoder mounting accessories: aluminum coupling shaft diameter of 6mm  
aluminum coupling shaft diameter of 10mm

For more accessories please refer to the attached section

EK5228-0 / 9

EZ5228-0 / 9

F30-2520-0606

F30-3025-1010

## Shaft version - Dimensions

Clamping flange, Ø10mm Shaft diameter

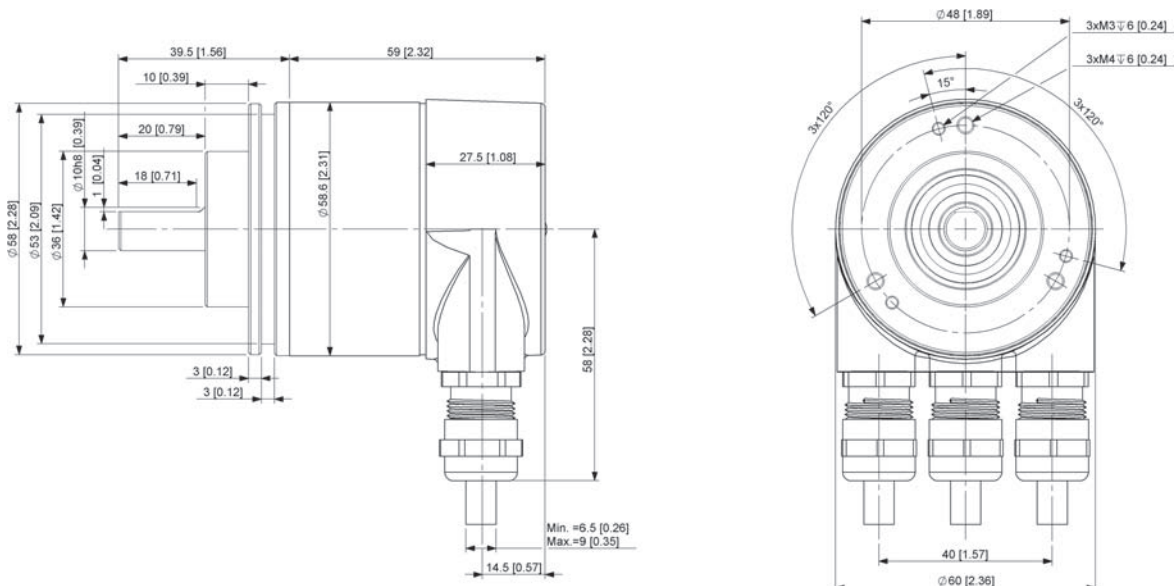



Synchro flange, Ø6mm Shaft diameter

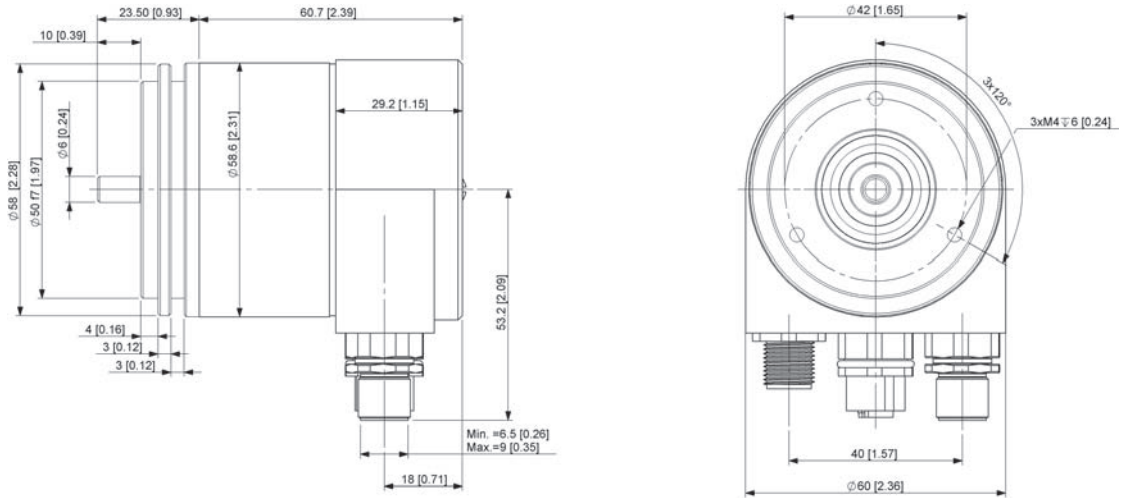

## hollow shaft - Dimensions

Blind hollow shaft

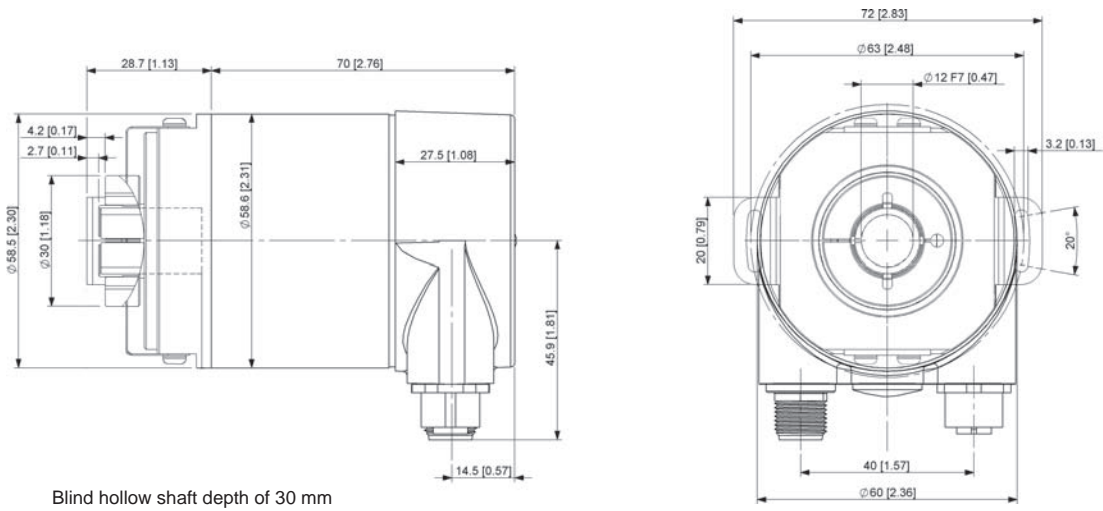

Blind hollow shaft depth of 30 mm



## Order code- shaft version

HC4 - 5 8 A - X X X X X - X X X X - X  
**Series - Standard**    A    B    C    D E F G H

### A Code

B = Binary

### B singleturn resolution

12 = 12 bit  
 13 = 13 bit  
 16 = 16 bit

### C laps

12 = 12 bit  
 14 = 14 bit

### D Flange Type

1 = Clamping flange , IP65  
 2 = Clamping flange , IP67  
 3 = Synchro flange , IP65  
 4 = Synchro flange , IP67

### E Shaft diameter

2 =  $\varnothing$  6x10mm  
 5 =  $\varnothing$  10x20mm

### F output / Power supply

3 = Profibus-DP output / 10 ... 30 VDC power supply

### G Connection

1 = removable bus terminal cover  
 Radial , 3x cable gland fitting  
 2 = with removable terminal coupling junction box,  
 Radial connector 3xM12

### H function

BLANK = No additional features  
 S = with reset button

## Order code- Hollow shaft

HC4 - 5 8 C - X X X X X - X X X X - X  
**Series - Standard**    A    B    C    D E F G H

### A Code

B = Binary

### B singleturn resolution

12 = 12 bit  
 13 = 13 bit  
 16 = 16 bit

### C laps

12 = 12 bit  
 14 = 14 bit

### D Flange Type

8 = Flying wing with fixed connectors , IP65

### E Shaft diameter

4 =  $\varnothing$  8mm  
 5 =  $\varnothing$  10mm  
 6 =  $\varnothing$  12mm  
 7 =  $\varnothing$  14mm  
 8 =  $\varnothing$  15mm

### F output / Power supply

3 = Profibus-DP output / 10 ... 30 VDC power supply

### G Connection

1 = removable bus terminal cover  
 Radial , 3x cable gland fitting  
 2 = with removable terminal coupling junction box,  
 Radial connector 3xM12

### H function

BLANK = No additional features  
 S = with reset button

## Absolute multiturn DeviceNET HC4-58



- Shape 58mm solid and reliable, suitable for applications in engineering vehicles and other industries
- Wide operating temperature range -40 ° C ... + 85 °
- DeviceNET interface, using the latest fieldbus protocol
- Optical sensor technology, resolution up to 16bits
- Multiturn mechanical gear system, Laps of up to 14 bits
- M12 and other connections to choose



Mechanical characteristics			DeviceNET interface characteristics		
Max.speed	12000 min <sup>-1</sup>		Interface Type	DeviceNET interface	
Starting torque	0.03 N.m MAX		Output circuit	Using electrically isolated optocoupler	
Moment of inertia	≤ 30 gcm <sup>2</sup>		Baud rate	≤ 500 Kbit / s (can be set by software)	
Shaft load capacity -radial	110 N		Code	Binary code	
Shaft load capacity -axial	40 N		Singleturn resolution	Max.16 bits	
Protection acc.to EN 60 529	Optional IP65/ IP67		Laps	Max.14 bits	
Operation temperature	-40 - 85°C		Profile	DeviceNET interface complies ISO/DIS 11898	
Materials	Shaft: Stainless steel;		Node address	1 ... 64 (Via rotary switch setting)	
Weight	About 0.325 kg		Termination resistors	via DIP switch setting	
shock resistance	1000m/s <sup>2</sup> , 6ms		Electrical life	> 10 <sup>5</sup> h	
vibration resistance	100m/s <sup>2</sup> , 10-2000Hz				
Mechanical life Fa/Fr	40/60 262	40/80 110	40/110 42		
General characteristics			DeviceNET interface complies with ISO / DIS 11898		
Power supply	10 ... 30 VDC		The following parameters are programmable modification		
Power consumption	Typical 100 mA, max 230 mA		-Counting direction		
Drive circuit	RS 485		-Singleturn resolution		
Start time	< 250 ms		-Total Resolution		
Output short circuit protection	YES		-Baud rate and node address		
Reverse polarity connection protection	YES		-Prefabricated value		
UL-approval	File 251481		-Terminating resistor		
CE compliant	EN 61000-6-4; EN61000-6-2				

### Terminantl assignment

Connection for junction boxes and connectors when 2xM12

Description	IN					OUT		
	+V	0 V	CAN(GND)	CAN(Low)	CAN(High)	CAN(GND)	CAN(Low)	CAN(High)
Junction Box Wiring	+	--	G	L	H	G	L	H
2 X M12 connector*	2	3	1	5	4	1	5	4

\* 2 X M12 connector to connect the way, the bus entrance to the needle seat, bus seat outlet holes, the power supply section that connection 2,3 needles with an internal short circuit in the encoder.

# Absolute Encoders-Multiturn

When the connection is the M12 connector

Description	IN				
	+V	0 V	CAN(GND)	CAN(Low)	CAN(High)
M12 connector	2	3	1	5	4

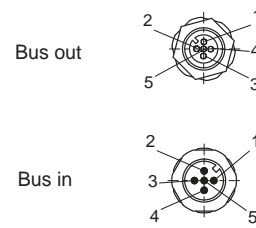

## Mounting Accessories

Cable connector: M12 Self-assembly plug (hole end)

Self-assembled M12 connector (pin end)

Shaft encoder mounting accessories: aluminum coupling shaft diameter of 6mm

Spring steel coupling shaft diameter of 10mm

For more accessories please refer to the attached section

EK5212-0 / 9

EZ5212-0 / 9

F30-3025-0606

F20-5025-1010

## Shaft - Dimensions

Clamping flange, Ø10mm Shaft diameter

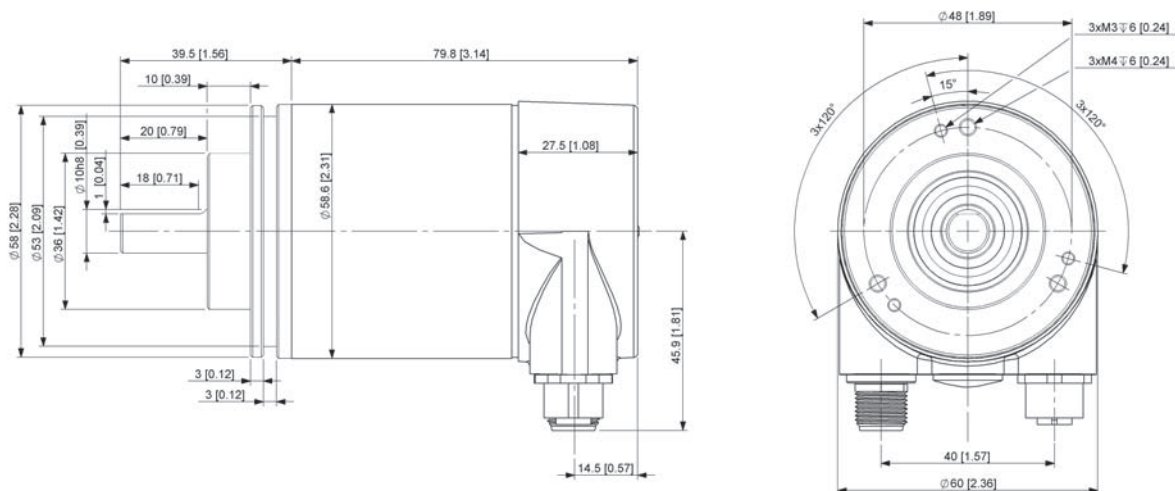

Synchro flange, Ø10mm Shaft diameter

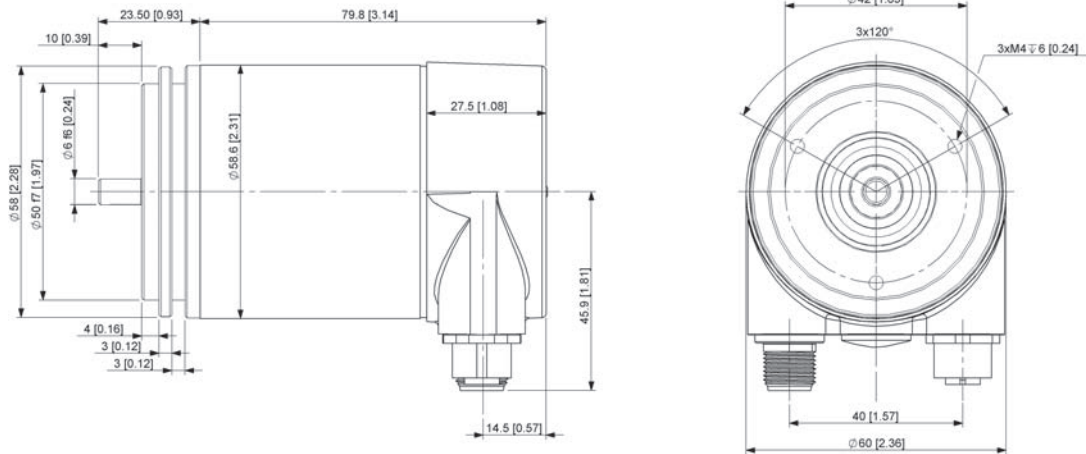

## Hollow shaft type - Dimensions

Blind hollow shaft

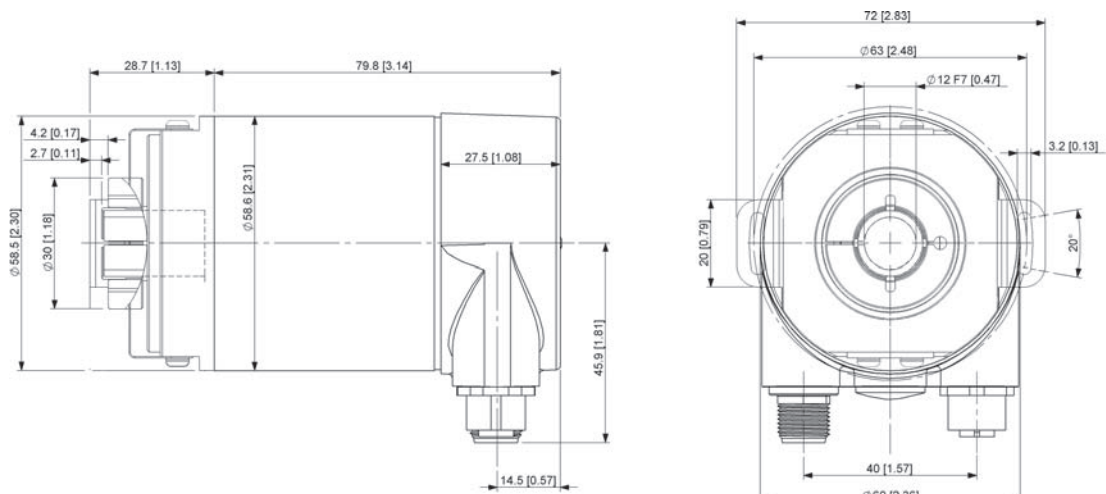

Blind hollow shaft depth of 30 mm

# Absolute Encoders-Multiturn

## Order code- shaft version

HC4 - 5 8 A - X X X X X - X X X X - X  
**Series - Standard**    A    B    C    D    E    F    G    H

### A Code

B = Binary

### B singleturn resolution

12 = 12 bit  
 13 = 13 bit  
 16 = 16 bit

### C Laps

12 = 12 bit  
 14 = 14 bit

### D Flange Type

1 = Clamping flange , IP65  
 2 = Clamping flange , IP67  
 3 = Synchro flange , IP65  
 4 = Synchro flange , IP67

### E Shaft diameter

2 =  $\varnothing$  6x10mm  
 5 =  $\varnothing$  10x20mm  
 6 =  $\varnothing$  12x20mm

### F output / Power supply

6 = DeviceNET output / 10 ... 30 VDC  
 power supply

### G Connection

2 = with removable terminal coupling junction box,  
 Radial connector 2xM12  
 5 = radial connector 1XM12

### H function

BLANK = No additional features

## Order code- Hollow shaft

HC4 - 5 8 C - X X X X X - X X X X - X  
**Series - Standard**    A    B    C    D    E    F    G    H

### A Code

B = Binary

### B singleturn resolution

12 = 12 bit  
 13 = 13 bit  
 16 = 16 bit

### C Laps

12 = 12 bit  
 14 = 14 bit

### D Flange Type

8 = Flying wing with fixed  
 connectors , IP65  
 9 = Flying wing with fixed  
 connectors , IP67

### C Shaft diameter

2 =  $\varnothing$  6 mm  
 4 =  $\varnothing$  8 mm  
 5 =  $\varnothing$  10 mm  
 6 =  $\varnothing$  12 mm  
 7 =  $\varnothing$  14 mm  
 8 =  $\varnothing$  15 mm

### F output / Power supply

6 = DeviceNET output / 10 ... 30 VDC  
 power supply

### G Connection

2 = with removable terminal coupling junction box,  
 Radial connector 2xM12  
 5 = radial connector 1XM12

### H function

BLANK = No additional features

## Absolute multiturn CANopen / CANlift HC4-58



- Shape 58mm solid and reliable, suitable for applications in engineering vehicles and other industries
- Wide operating temperature range -40 ° C ... + 85 ° C
- CANopen / CANlift interface, using the latest fieldbus protocol
- Optical sensor technology, resolution up to 16bits
- Multiturn mechanical gear system, Laps of up to 14 bits
- Has a direct outlet, M12 and other connections to choose from



Mechanical characteristics		CANopen / CANlift interface parameters	
Max.speed	12000 min <sup>-1</sup>	Interface Type	CANopen / CANlift interface
Starting torque	0.03 N.m MAX	Output circuit	Data bus interface, using electrically isolated optocoupler
Moment of inertia	≤ 30 gcm <sup>2</sup>	Baud rate	≤ 1 Mbit / s (can be set by software)
Shaft load capacity -radial	110 N	Transmission cycle	> 1ms
Shaft load capacity -axial	40 N	Code	Binary
Protection acc.to EN 60 529	Optional IP65 IP67	Singleturn resolution	Max.16 bits
Operation temperature	-40 - 85°C	Laps	Max.14 bits
Materials	Shaft : Stainless steel ; Flange, housings : aluminium alloy	Profile	CANopen DS406 accord CANlift comply DS417
Weight	About 0.325 kg	Node address	1 ... 127, the default address 32 (Via rotary switch setting)
Shock resistance EN 60068-2-29	1000m/s <sup>2</sup> , 6ms	Terminal resistance	Built-in (via DIP switch or software)
Vibration resistance EN 60068-2-27	100m/s <sup>2</sup> , 10-2000Hz	Electrical life	> 10 <sup>5</sup> h
Mechanical life Fa/Fr	40/60    40/80    40/110 262       110       42	CANopen interface protocol accord DS406	
<b>GE parameters</b>		CANlift interface protocol accord DS417	
Supply voltage	10 ... 30 VDC	The following parameters are programmable modification	
Power	Typical 100 mA, max 230 mA	-Counting direction	
Drive circuit	RS 485	-Resolution	
Start time	< 250 ms	- Prefabricated value, baud rate and node address	
Output short circuit protection	With	-Two limit points and eight cam	
Reverse polarity connection protection	With	-Terminating resistor	
UL certification	File 251481	-Transmit mode: rotation mode, periodic transmission mode, synchronous mode	
CE compliant	EN 61000-6-4; EN61000-6-2		

### Terminal assignment

Connection for junction boxes and connectors when 2x M12

Description	IN					OUT		
	+V	0 V	CAN(GND)	CAN(Low)	CAN(High)	CAN(GND)	CAN(Low)	CAN(High)
Junction Box Wiring	+	--	G	L	H	G	L	H
2 X M12 connector*	2	3	1	5	4	1	5	4

\* 2 X M12 connector to connect the way, the bus entrance to the needle seat, bus seat outlet holes, the power supply section that connection 2,3 needles with an internal short circuit in the encoder.

# Absolute Encoders-Multiturn

## Connection to the cable outlet and connectors

Description	IN				
	+V	0 V	CAN(GND)	CAN(Low)	CAN(High)
M12 connector	2	3	1	5	4
Cable color	White	Brown	Green	Pink	Yellow

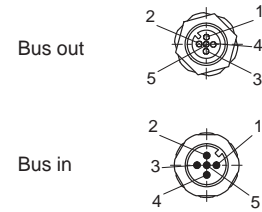

## Mounting Accessories

Mating connector: M12 Self-assembly plug (female end)

Self-assembled M12 connector (pin end)

Shaft encoder mounting accessories: aluminum coupling shaft diameter of 6mm

Spring steel coupling shaft diameter of 10mm

For more accessories please refer to the attached section

EK5212-0 / 9

EZ5212-0 / 9

F30-3025-0606

F20-5025-1010

## Axis - Dimensions

Clamping flange, Ø10mm Shaft diameter

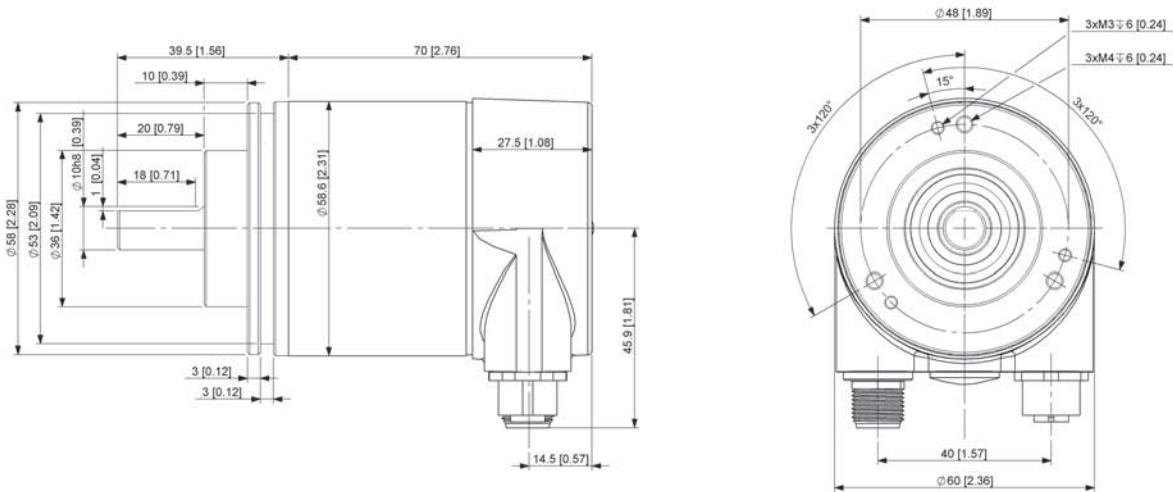

Clamping flange, Ø 10mm Shaft diameter

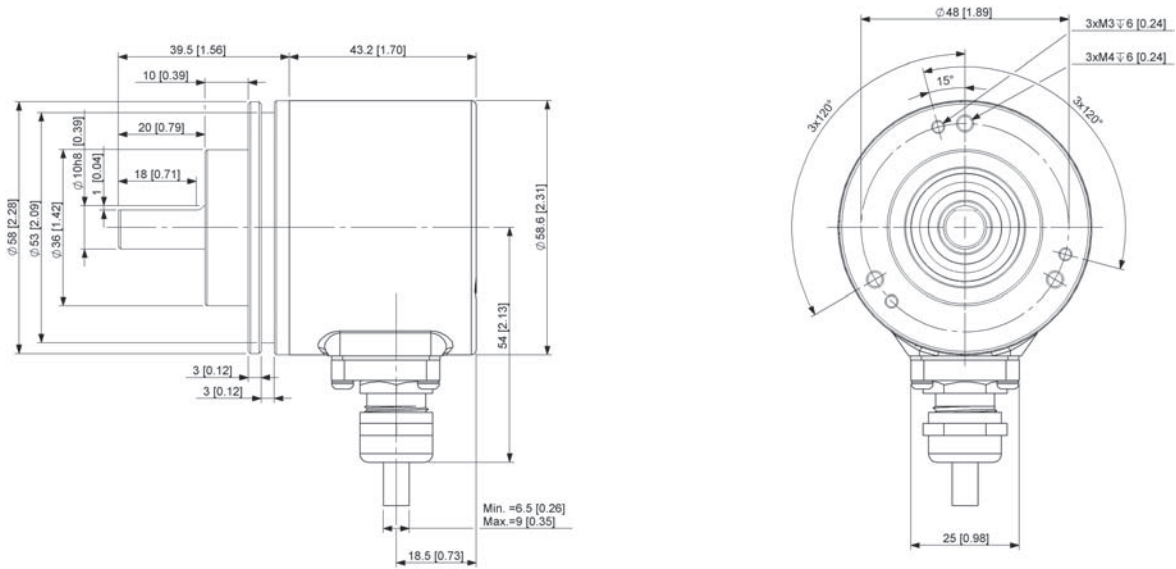

Synchro flange Ø 6mm Shaft diameter, connectors

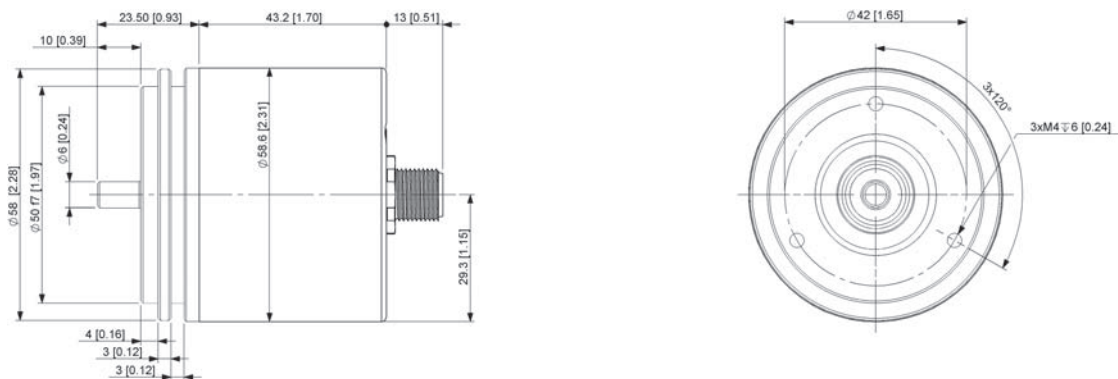

Synchro flange Ø 6mm Shaft diameter, cable outlet

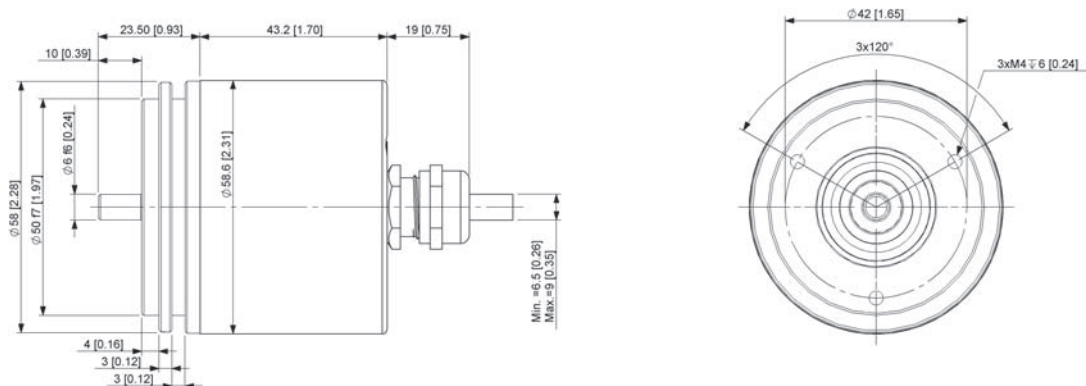



## Sleeve type - Dimensions

Blind hollow shaft

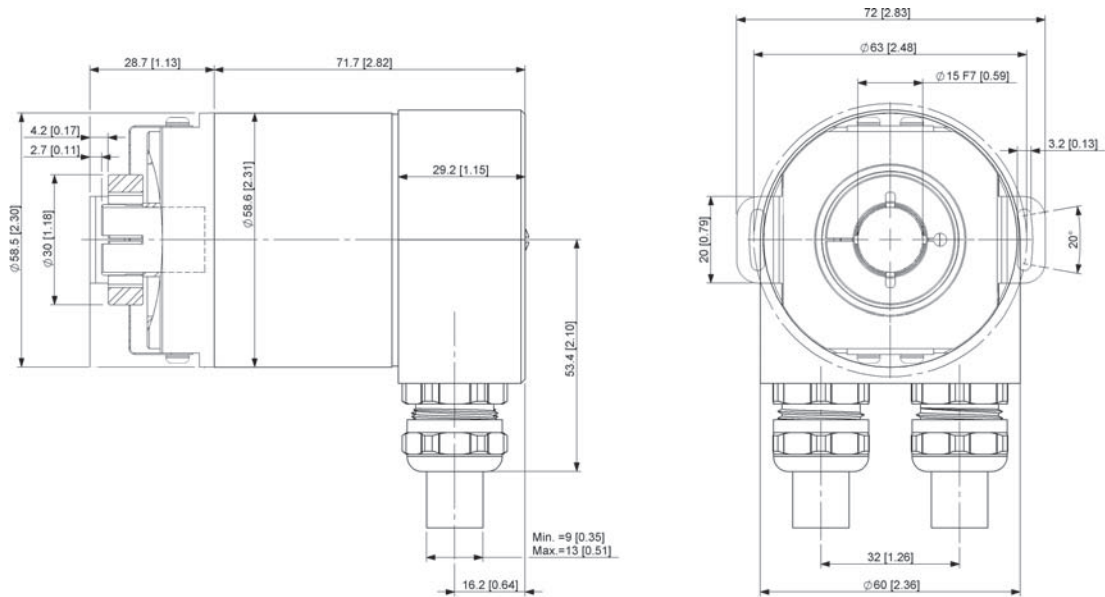

Blind hollow shaft depth of 30mm

### Order code- shaft version

HC4 - 5 8 A - X X X X X - X X X X - X  
**Series - Standard**    A   B   C   D   E   F   G   H

#### A Code

B = Binary

#### B Singleturn resolution

12 = 12 bit  
 13 = 13 bit  
 16 = 16 bit

#### C Laps

12 = 12 bit  
 14 = 14 bit

#### D Flange Type

1 = Clamping flange , IP65  
 2 = Clamping flange , IP67  
 3 = Synchro flange , IP65  
 4 = Synchro flange , IP67

#### E Shaft diameter

2 =  $\varnothing$  6x10mm  
 5 =  $\varnothing$  10x20mm  
 6 =  $\varnothing$  12x20mm

#### F output / Power supply

4 = CANopen / 10 ... 30 VDC power supply  
 5 = CANlift / 10 ... 30 VDC power supply

#### G Connection

1 = with removable terminal coupling junction box,  
 Radial 2x cable nut  
 2 = with removable terminal coupling junction box,  
 Radial connector 2xM12  
 3 = axial connector 1XM12  
 5 = radial connector 1XM12  
 6 = radial 1 m cable

#### H function

BLANK = No additional features

### Order code- Hollow shaft

HC4 - 5 8 C - X X X X X - X X X X - X  
**Series - Standard**    A   B   C   D   E   F   G   H

#### A Code

B = Binary

#### B Singleturn resolution

12 = 12 bit  
 13 = 13 bit  
 16 = 16 bit

#### C Laps

12 = 12 bit  
 14 = 14 bit

#### D Flange Type

8 = Flying wing with fixed  
 connectors , IP65  
 9 = Flying wing with fixed  
 connectors , IP67

#### E Shaft diameter

2 =  $\varnothing$  6 mm  
 4 =  $\varnothing$  8 mm  
 5 =  $\varnothing$  10 mm  
 6 =  $\varnothing$  12 mm  
 7 =  $\varnothing$  14 mm  
 8 =  $\varnothing$  15 mm

#### F output / Power supply

4 = CANopen / 10 ... 30 VDC power supply  
 5 = CANlift / 10 ... 30 VDC power supply

#### G Connection

1 = with removable terminal coupling junction box,  
 Radial 2x cable nut  
 2 = with removable terminal coupling junction box,  
 Radial connector 2xM12  
 5 = radial connector 1XM12  
 6 = radial 1 m cable

#### H function

BLANK = No additional features

## Draw wire encoder



- Linear Measuring
- Measuring range: 3 meters to 10 meters optional
- High repetition accuracy, high resolution, high speed stretch
- Tensile aluminum housing, rugged and reliable, can be used outdoors, long life
- Optional encoder used in conjunction with the corresponding
- Can be used for construction machinery and engineering vehicle length and angle measurement



### Mechanical characteristics

measuring length	3 m	5 m	10 m
Accuracy	±0.02 %	±0.02 %	±0.02 %
repeatability	±0.002%	±0.002%	±0.002%
Drum perimeter	260 mm	315 mm	315 mm
steel wire diameter	0.8 mm	1 mm	1 mm
Min.extension force	5.5 N	4 N	8 N
Max.extension force	9 N	16 N	21 N
Working speed	2.0 m/s	2.0 m/s	2.0 m/s
Materials	Housings : aluminium alloy	Housings : aluminium alloy	Housings : aluminium alloy
	steel : Stainless steel	steel : Stainless steel	steel : Stainless steel
Working life	The whole stretch 5 million times	The whole stretch 5 million times	The whole stretch 5 million times

Note: If the maximum extension length is exceeded, cables and sensors will be damaged.

### Electrical parameters

Electrical characteristics of the relevant parameters in accordance with the matching encoder, the encoder details, refer to the relevant sections.

### Works

Cable box work is: through a wound in accordance with the rules on fixed wire diameter drum, driven linear displacement sensor devices that convert electrical signals, which is characterized by high accuracy, fast dynamic response, long service life.

"Measuring Range" and "pre-stretched length" terms to describe

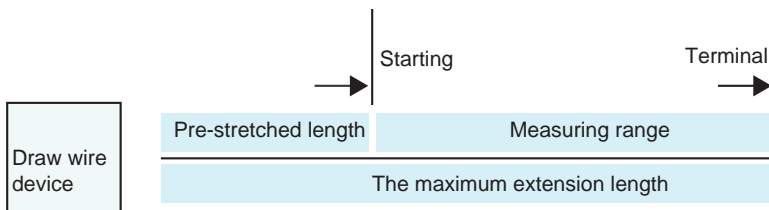
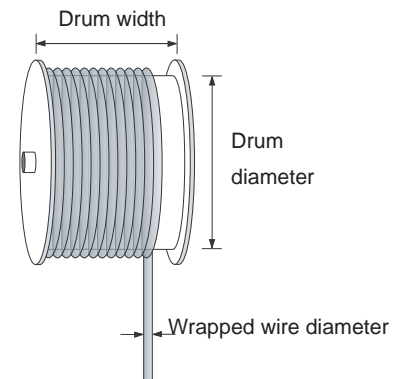



Clinometer HD-M



- Clinometer allows measurement of uniaxial or biaxial inclination
- High resolution precision: error of 0.1 °, with a resolution of 0.01 °
- Optional current, voltage and CANopen interface with RS-232 interface can be programmed inclinometer
- High degree of protection up to IP69K available for harsh mechanical environments
- For vehicle technology, solar installations, lifting, lifting equipment and construction vehicles



Mechanical characteristics		Analog interface parameters	
Weight	200 g	Analog current output	4 ... 20 mA
Protection acc.	IP 68 / IP 69K	Maximum Load Resistance	270 Ω (supply voltage is 10 V DC time) 500 Ω (supply voltage is 15 V DC time)
Operation temperature	- 40 °C ... 80 °C	Analog voltage output	Voltage output 0 ... 5 V, 0 ... 10 V
Storage temperature	- 40 °C ... 85 °C	The minimum load resistance	10 kΩ (when 12 VDC powered)
Materials	Aluminum or plastic PBT	RS232 interface characteristics	Max. 115200 bits (default 9600 bits)
Vibration resistance EN 60068-2-27	1000m/s <sup>2</sup> , 6ms	Transfer baud rate	
Vibration resistance	≤ 200m/s <sup>2</sup> , 58 Hz to 2000 Hz		
MTTF	300 years		
Common interface parameters		CANopen interface parameters	
Supply voltage	10 ... 30 VDC	Interface Type	CANopen Profil DS 410
power consumption (no load)	analog 20 mA / CANopen 58mA	Code	Binary code
Measuring axes	An axis (Z) or two axes (X, Y)	Baud rate	Maximum 1 Mbit / s (default 125 K) programmable
Uniaxial measuring range	90 °, 120 °, 180 °, 270 °, 360 °	Node address	Default 1 (0 ... 127)
Biaxial measuring range	± 10 °, ± 20 °, ± 40 °, ± 60 °, ± 80 °	Termination resistors	Off by default, can be programmed by software
Absolute accuracy	0.1 °	Transmission cycle	≥ 1 ms
Resolution	0.01 °	CANopen interface protocol in line with DS 410	
linearity	± 0.02%	The following parameters are programmable Review:	
temperature excursion	0.004 ° / K	- Resolution	
Response time	125 ms	- Prefabricated value	
Programmable parameters	Zero position, direction, range	- Two limit points	
Reverse polarity protection	There is	- Baud rate and node address	
Short circuit protection	There is	- Heartbeat function	
Electrical life	> 100000h	- Transmit mode: Polling mode, cycle transmit mode, synchronous mode	
Complies with CE certification	EN 61000-6-2: 2005; EN 61000-6-4: 2007-09		
RoHS Compliant	2011/65 / EU standards		

Terminanl assignment

Signal	Ub	RxD	TxD	0V	X-axis output	Set the input	Y-axis output	Set the input
Cable ( color)	White	Brown	Green	Yellow	Grey	Pink	Blue	Red
8-pin M12 connector pin holder (pin number)	1	2	3	4	5	6	7	8

Top view of the socket

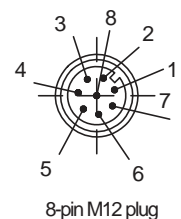

# Clinometer

## CANopen terminal configuration

Signal	+V	0 V	CAN(GND)	CAN(Low)	CAN(High)
M12 connector	2	3	1	5	4
Cable color	White	Brown	Green	Pink	Yellow

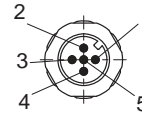

Uniaxial working schematic

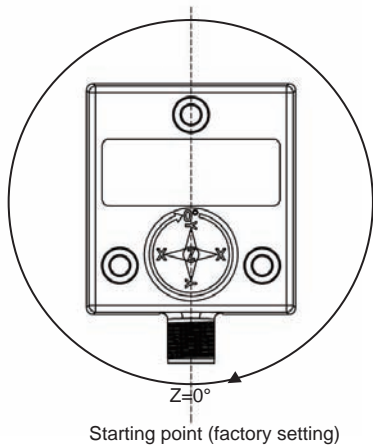

Biaxial working schematic

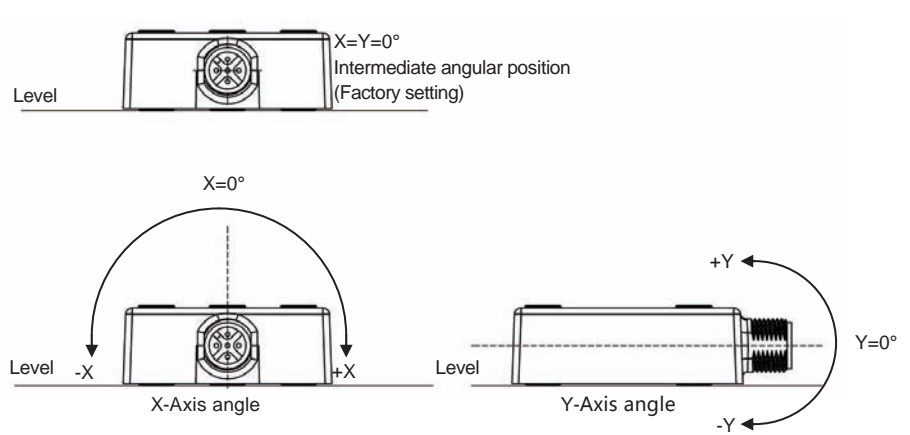

### Clinometer - Order code :

**HD - M** X X X X - X  
 A B C D E

#### A detection direction

- 1 = Single-axis ( Z )
- 2 = Biaxial ( X,Y )

#### B Range

Single-axis	Biaxial
1 = 90°	±10°
2 = 120°	±20°
3 = 180°	±40°
4 = 270°	±60°
5 = 360°	±80°

#### C Supply voltage / output circuit

- 1 = 4 ... 20 mA output + RS232 / 10 ... 30 VDC power supply
- 2 = 0 ... 5 V output + RS232 / 10 ... 30 VDC power supply
- 3 = 0 ... 10 V output + RS232 / 10 ~ 30 VDC power supply
- 4 = CANopen output / 10 ... 30 VDC power supply

#### D Materials

- F = Fiber reinforced PBT material
- AL= Aluminum Alloy

#### E Connection

- 1 = Cable outlet
- 2 = M12 8-pin connector (without mating connector plug) (Analog)
- 3 = M12 5-pin connector (without mating connector plug) (CANopen)

Torque support slot - a short paragraph

Delivery includes: an elastic element (plastic)  
1 mounting screw

Connectivity applications: cylindrical pin (not supplied)

Order code: FL-0001

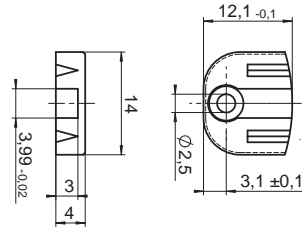

Torque support slot - long section

Delivery includes: an elastic element (plastic)  
1 mounting screw

Connectivity applications: cylindrical pin (not supplied)

Order code: FL-0002

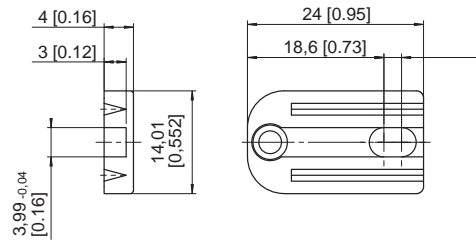

Long cylindrical threaded pin

For torque support slot

Short paragraph

Long section

Order code: FL-0003

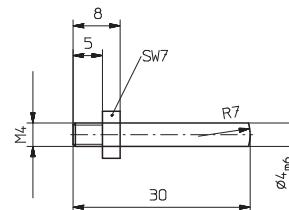

Torque support slot - a short paragraph

Delivery includes: an elastic element (stainless steel)  
2 mounting screws

Connectivity applications: cylindrical pin (not supplied)

Order code: FL-0004

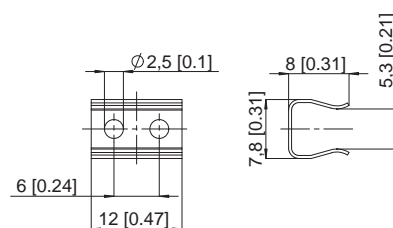

Torque support slot - long section

Delivery includes: an elastic element (stainless steel)  
2 mounting screws

Connectivity applications: cylindrical pin (not supplied)

Order code: FL-0005

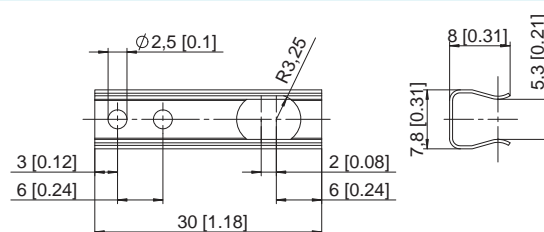

Long cylindrical threaded pin

For torque support slot

Short paragraph

Long section

Order code: FL-0006

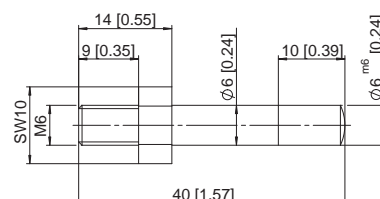

## Spring leaves

Installation of spring, for limited axial movement and for the runout  
 Order code : FL-0007



## Trolley

Trolley  
 For slight axial movement and radial runout, for large bush encoder

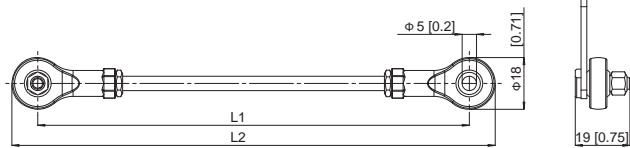
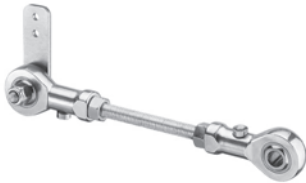

Order code	L1	L2
FL-0070	70 [2.76]	88 [3.46]
FL-0100	100 [3.94]	118 [4.65]
FL-0150	150 [5.91]	168 [6.61]

## 导向轮

导向轮，用于拉绳编码器的钢丝绳的方向的改变  
 订货代码：FL-0008



L-bracket

For shaft encoder installation

Delivery include: L-bracket (aluminum)

3 for encoder mounting screws

Connectivity applications: two screws (fixing)  
Not available

Order code: FL-0009

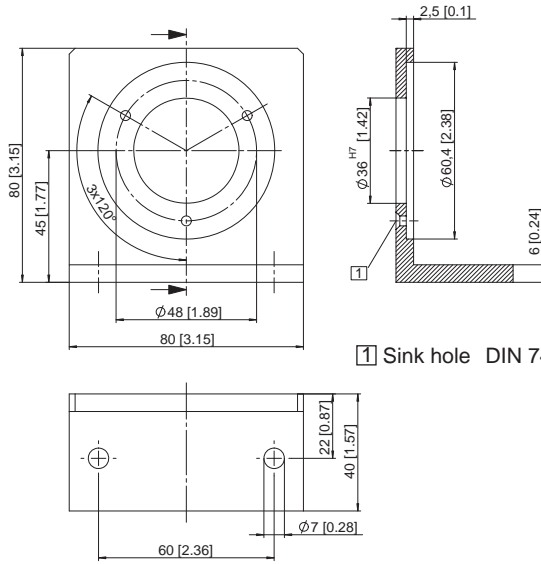

1 Sink hole DIN 74-Hm6

Eccentric connector

For encoder with synchro flange

Eccentric connector

For synchro flange encoder sizes available

Material: ACu Zn 39 Pb 3

Finishing: nickel

Delivery includes: three eccentric connector

3 screws

(Set includes at least three eccentric connector)

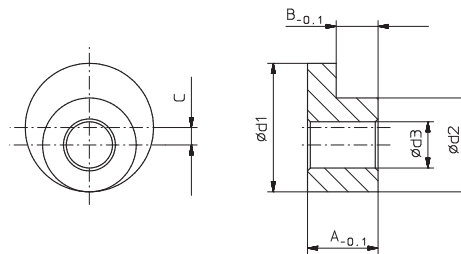

Ordering code	D1	D2	D3	A	B	C
FL-0010	6.8	5	2.8	3.5	2.25	0.9
FL-0011	8.9	6.5	3.2	5.6	2.9	1.2



## Couplings



**Description and Application:**  
Ease of fabrication error and the drive shaft misalignment caused by an alignment error encoder and the drive shaft. If the rigid connection of these errors will result in increased wear of the bearing and cause premature failure of the encoder. By using couplings, which can compensate for the error, thereby reducing the bearing load to a minimum.

These three pairs of error are: radial, angular and axial misalignment. For no torque but flexible couplings, axial shaft displacement can be alleviated for the static pressure inside the coupling. Radial and angular deviation inside the encoder can relieve the stress of the form. Based on the different types of coupling, special attention should guarantee a minimum radial displacement of the shaft.

### Installation Guide:

1. Check the shaft displacement; as detailed technical parameters
2. Place the coupling on the shaft and adjust.
3. Carefully clamp screws. Avoid tight.

The installation process to prevent damage and excessive bending coupling.

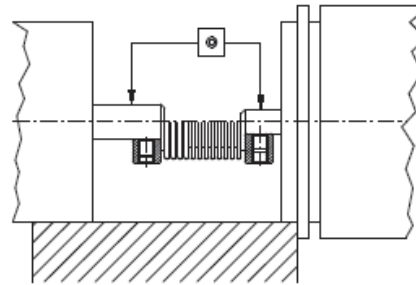

Technical parameters				
Type	Bellows	Spring steel	Aluminum	Flexible couplings
Maximum speed	10000 min <sup>-1</sup>	3000 min <sup>-1</sup>	6000 min <sup>-1</sup>	3000 min <sup>-1</sup>
Maximum torque	80 Ncm	150 Ncm	120 Ncm	50 Ncm
The maximum radial displacement	±0.25 mm	±1.5 mm	±0.35 mm	±2 mm
The maximum axial displacement	±0.4 mm	±1 mm	±0.5mm	±2 mm
The maximum angular displacement	±4°	±5°	±4°	±10°
Torque elasticity	150 Nm/rad	150 Nm/rad	16 Nm/rad	13 Nm/rad
Axial elasticity	25 N/mm	25 N/mm	45 N/mm	13 N/mm
Moment of inertia	8 gcm <sup>2</sup>	15 gcm <sup>2</sup>	29 gcm <sup>2</sup>	41 gcm <sup>2</sup>
The maximum tightening torque	150Ncm	300Ncm	100Ncm	100Ncm
Weight	About 15g	About 100g	About 34g	About 33g
Material	Stainless steel	Stainless steel	Aluminum	Polyurethane and stainless steel
Gauge	6/6 10/10 Other sizes can be set	6/6 10/10	6/6 10/10	6/6 10/10

Couplings

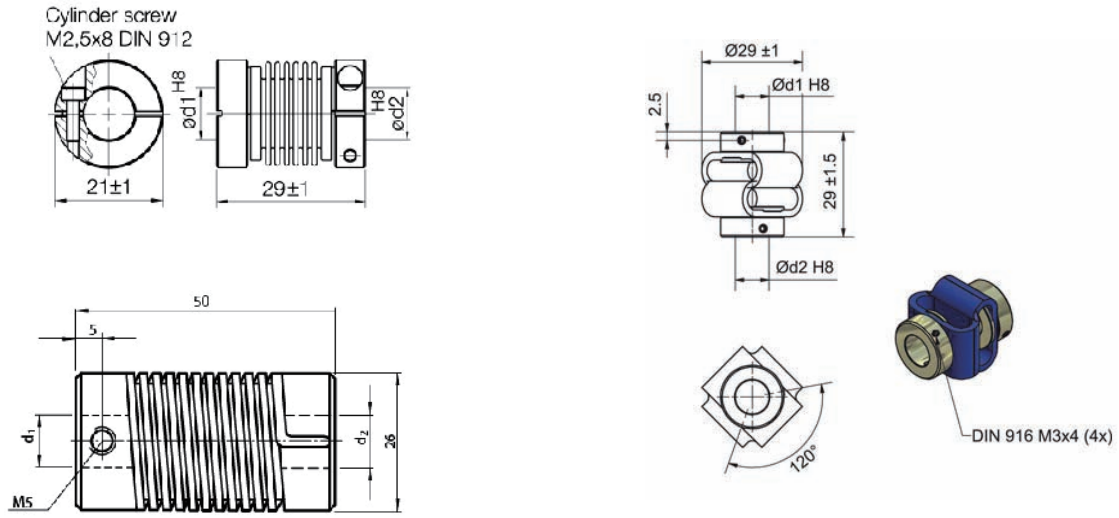

Couplings - Order code :

**F XX - XXXX - XXXX**  
                          
**A    B    C    D    E**

A coupling type  
 10 = Bellows coupling  
 20 = Spring steel couplings  
 30 = Aluminum couplings  
 40 = Flexible coupling

B coupling length  
 As the length L = 50mm, namely 50  
 Available in various sizes

D aperture d1  
 As d1 = 6mm, namely 06  
 Available in various sizes

C coupling outside diameter  
 Such as the outer diameter  $\varphi = 25$ mm, namely 25  
 Available in various sizes

E aperture d2  
 As d2 = 6mm, namely 06  
 Available in various sizes

## Encoder Accessories

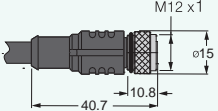
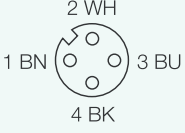
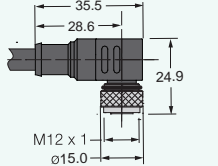
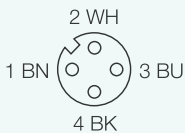
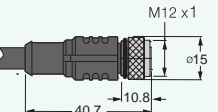
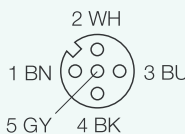
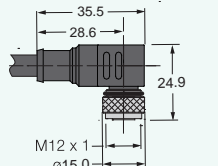
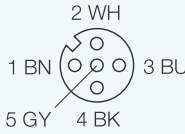
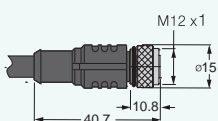
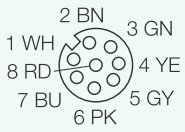
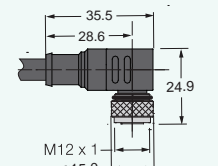
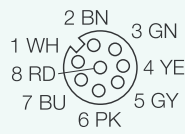
4-pin M12 prefabricated cable	Pinout	Cable length	Type NO.	ID NO.	Applicable encoder
<b>Straight Female</b>					
		2m 5m 10m	EK4-2M/P00 EK4-5M/P00 EK4-10M/P00	10011010 10011011 10011012	Suitable for Profibus-DP Power Supply
<b>Right angle Female</b>					
		2m 5m 10m	ELK4-2M/P00 ELK4-5M/P00 ELK4-10M/P00	10011040 10011041 10011042	Suitable for Profibus-DP Power Supply
5-pin M12 prefabricated cable	Pinout	Cable length	Type NO.	ID NO.	Applicable encoder
<b>Straight Female</b>					
		2m 5m 10m	EK4.5-2M/P00 EK4.5-5M/P00 EK4.5-10M/P00	10011020 10011021 10011022	Suitable for clinometer
<b>Right angle Female</b>					
		2m 5m 10m	ELK4.5-2M/P00 ELK4.5-5M/P00 ELK4.5-10M/P00	10011050 10011051 10011052	Suitable for clinometer
8-pin M12 prefabricated cable	Pinout	Cable length	Type NO.	ID NO.	Applicable encoder
<b>Straight Female</b>					
		2m 5m 10m	EK8-2M/P00 EK8-5M/P00 EK8-10M/P00	10011810 10011811 10011812	Applies to incremental and SSI
<b>Right angle Female</b>					
		2m 5m 10m	ELK8-2M/P00 ELK8-5M/P00 ELK8-10M/P00	10011810 10011811 10011812	Applies to incremental and SSI

M23 prefabricated cable -12 pin	Pinout	Cable length	Type NO.	Applicable encoder
---------------------------------	--------	--------------	----------	--------------------

Straight Female , PVC Cable  
(6 x 2 x 0.14 mm<sup>2</sup>)

Pin program  
Clockwise

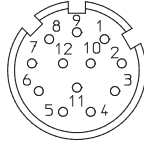

2m  
5m  
10m

GNK12-10-2M/P00/EC01  
GNK12-10-5M/P00/EC01  
GNK12-10-10M/P00/EC01

Suitable for incremental  
encoder

Pin	1	2	3	4	5	6	7	8	9	10	11	12
Cable color	PK	RD/BU	BU	RD	GN	YE	-	GY	-	WH	GY/PK	BN

M23 prefabricated cable -12 pin	Pinout	Cable length	Type NO.	Applicable encoder
---------------------------------	--------	--------------	----------	--------------------

Straight Female , PVC Cable  
(6 x 2 x 0.14 mm<sup>2</sup>)

Pin program  
Clockwise

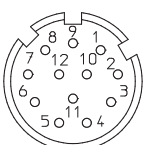

2m  
5m  
10m

GNK12-12-2M/P00/EC02  
GNK12-12-5M/P00/EC02  
GNK12-12-10M/P00/EC02

Suitable for absolute  
encoder

Pin	1	2	3	4	5	6	7	8	9	10	11	12
Cable color	WH	BN	GN	YE	GY	PK	BU	RD	BK	VT	GY/PK	RD/BU

## Encoder Accessories

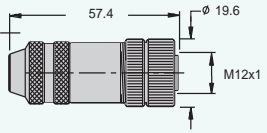
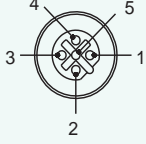
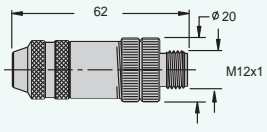
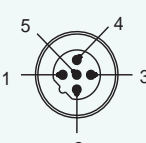
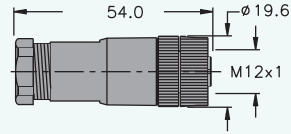
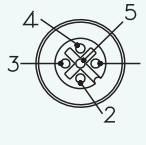
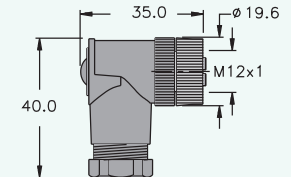
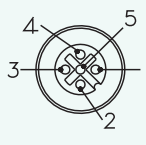
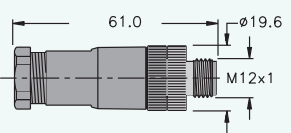
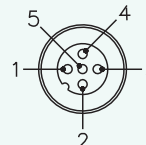
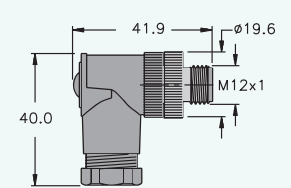
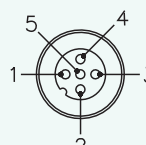
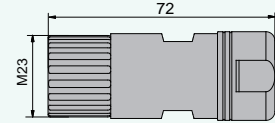
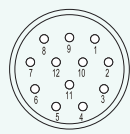
M12 field wiring connectors	Pinout	Description	Type NO.	ID NO.	Applicable encoder
		<p>M12x1 Straight Female, B- coded, 5-pin Metal housing shield Brass/Gold contacts PG9 cable gland Accept 6~8mm cable diameter Screw terminals 85 ° C, 125V, 4A</p>	EK5228-0/9	10091200	Absolute value of the Profibus-DP
		<p>M12x1 Straight Male, B- coded, 5-pin Metal housing shield Au plated brass contacts PG9 cable gland Accept 6~8mm cable diameter Screw terminals 85 ° C, 125V, 4A</p>	EZ5228-0/9	10091210	Absolute value of the Profibus-DP
M12 field wiring connectors	Pinout	Description	Type NO.	ID NO.	Applicable encoder
		<p>PA6+GF, Black PG 9 cable gland Accept 6~8mm cable diameter Screw terminals 85°C , 60 V, 4 A</p>	EK5212-0/9	10091002	DeviceNET absolute value and CANopen
		<p>PA6+GF, Black PG 9 cable gland Accept 6~8mm cable diameter Screw terminals 85°C , 60 V, 4 A</p>	ELK5212-0/9	10091012	DeviceNET absolute value and CANopen
		<p>PA6+GF, Black/Brass/Nicket PG 9 cable gland Accept 6~8mm cable diameter Screw terminals 85°C , 60 V, 4 A</p>	EZ5212-0/9	10091022	DeviceNET absolute value and CANopen
		<p>PA6+GF, Black/Brass/Nicket PG 9 cable gland Accept 6~8mm cable diameter Screw terminals 85°C , 60 V, 4 A</p>	ELZ5212-0/9	10091032	DeviceNET absolute value and CANopen
M23 field wiring connectors	Pinout	Description	Type NO.	ID NO.	Applicable encoder
M23 Straight Female Clockwise					
		<p>Brass M23 cable gland Accept 5~10mm cable diameter Screw terminals 85°C , 250V, 9A</p>	GNK1228-0/22	10095000	Applies to incremental and absolute

# **GSEE TECH**

## Encoders



- Tianjin Geneuo Technology Co., Ltd.
- Address: Technology Avenue South Jinghai Economic Area, Tianjin, China
- Tel : +86-22-68277298
- Fax : +86-22-68277161
- Zipcode : 301609
- Web : [www.gsee-tech.cn](http://www.gsee-tech.cn)  
[www.gsee-tech.com](http://www.gsee-tech.com)
- E-mail : [marketing\\_gsee@outlook.com](mailto:marketing_gsee@outlook.com)



Geneuo Weibo



Geneuo Wechat