

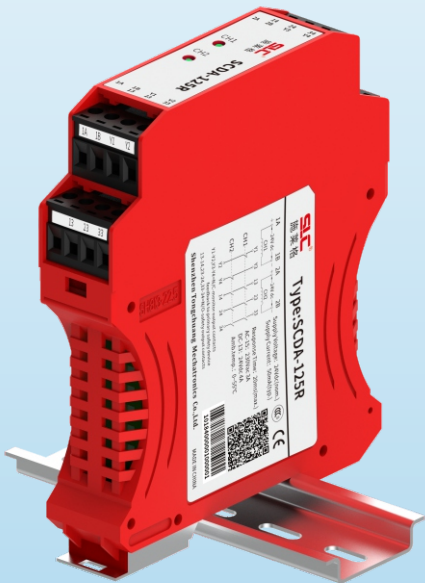

SCDA-125R Safety Relay Module



Product Overview

SCDA-125R safety relay interface module operation provides isolated redundant output for connecting DC safety control (such as safety light curtain or other safety module) to safety circuit.

The safety relay interface module follows the safety output action of the front-level safety device that controls it, and its output will be switched within 20ms delay.

The rated voltage of each normally open output of the safety relay interface module is up to 250Vac/dc, and the current is up to 6 A.

The safety relay interface module provides two set of normally closed contact (labeled Y1-Y2 and Y3-Y4) for external equipment monitoring (EDM) of pre-level safety equipment. The front-level safety equipment detects the failure of the safety relay interface module through these forced-guided (mechanical connection) contacts; in Category 3 or Category 4 applications achieved by ISO13849-1 safety level, these normally closed contacts must be monitored.

Characteristics

- ◆ SCDA-125R interface for front-level security equipment;
- ◆ The SCDA-125R safety relay interface module provides isolated safety output contacts for the front-level safety equipment with external equipment monitoring (EDM) capability for solid-state or hard contact output (such as safety light curtain or safety module, etc.);
- ◆ SCDA-125R provides 6A capacity four normally open redundant output channels;
- ◆ 3 normally open channels are connected in series by two relays with forced-guided safety module inside;
- ◆ Independent normally closed feedback output for each safety relay (external device monitoring EDM)
- ◆ individual indicator light for each safety relay;
- ◆ 24V DC operation;
- ◆ Standard 22.5mm thickness;
- ◆ Standard 35mm DIN rail installation;
- ◆ Removable terminals.



Warning

It is not an independent operating place protection equipment.

- ◆ This SCDA-125R is not an independent operating point protection equipment. Failure to correctly install operating point protection equipment on dangerous machinery will lead to serious injury or death.
- ◆ Reasonable installation of operating point protection equipment, such as safety light curtains and/or permanent fences, to protect personnel from dangerous machinery.



Important: Please read this before continuing

Users are responsible for complying with local and national laws, rules, norms and regulations related to the use of this product and its application, and Shenzhen Tong Chuang Mechatronics Technology Co., Ltd. makes every effort to provide complete application, installation, operation and maintenance instructions. If you have any questions about this product, please contact the appropriate application engineer.

It is the responsibility of the User to ensure that all machine operators, maintenance personnel, electricians and supervisors are fully familiar with and understand all instructions regarding the installation, maintenance and use of the Product, as well as the machinery and equipment it controls, and that the User and any person involved in the installation and use of the Product are fully familiar with all applicable standards.

Technical parameters

Performance parameter	
Standard	EN 60947-1, EN 60947-5-1
Operating voltage	24VDC±15%
Working current per channel	2W
Feedback output	2 channel normally closed output; (in series connected by four normally closed contacts of four relays CH1-CH2-CH3-CH4 with forced guide rods)
Safety output	3 channels normally opened output ; (each output is connected in series by two normally open contacts of two safety relays CH1-CH2 or CH3-CH4 with a forced guide rod)
Output response time	20ms Max
Output type	AC-15: 250 VAC, 3A / DC-13: 24 VDC, 4A
Protection	Transient voltage suppression
Indicator	2 green indicators show the status of the internal relay CH1 and CH2 respectively.
Current category	III
Pollution level	2
Vibrate	10Hz ~ 200Hz 5g(NO)
Working temp	0 ~ 55 °C
Protection level	IP20 (Note: When used, the safety relay must be placed in an environment where the shell protection level is higher than Ip54)
Mechanical life	40,000,000 times
Electrical life	500,000 times
Installation	Standard 35mm DIN rail installation

※Subject to product configuration and manufacturing process, the actual size and weight of the product may be different, please refer to the actual product

Panel description

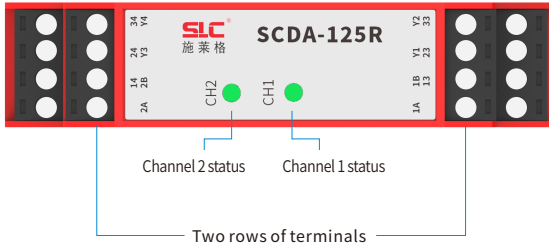

Block diagram

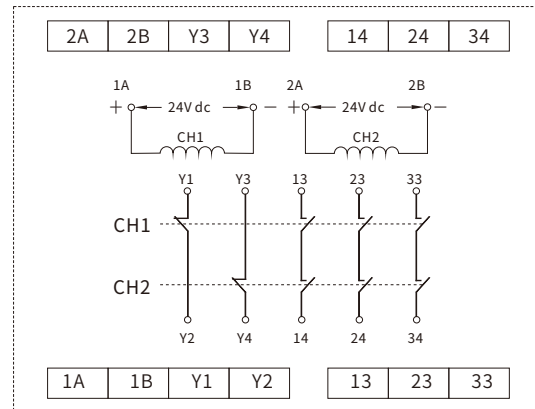

Requirements for front-level safety equipment

SCDA-125R is driven by single-channel or dual-channel front-level security equipment

For higher-risk applications, the design of the front-level safety device must meet ISO/IEC/EN category 3 or 4, performance level d or e, and IEC61508 SIL2 or 3 requirements that the interface module can only be used with the front-level safety device with external device monitoring function (see See the wiring diagram and the warning interface MPCE).

Each output channel of the front-level security equipment must at least:

Including a normally open forced guide (mechanical connection) contact or a solid-state 24V DC safe output (OSSD)

- (1) It can carry out self-state monitoring to generate a safety (OFF) state in the event of failure;
- (2) It can drive 50mA current at 24Vdc±15% voltage.

Note: Because the OSSD solid-state output on the front-stage safety equipment is often pulsed, the relay coil may produce an audible hum. As long as the pulse width is less than 500us (microseconds) and the duty-by (t_1/t_2) is greater than 500, this relay buzzer will not affect the function of the interface module.

Final Switching Equipment (FSD): A component of machine safety-related control. When the output signal switching equipment (OSSD) enters the shutdown state, it will interrupt the circuit of the machine's main control unit (MPCE).

Output Signal Switching Device (OSSD): A component of the electro-sensitive protection device (ESPE) connected to the machine control system. When the sensor device is started during normal operation, it will respond by entering the shutdown state.

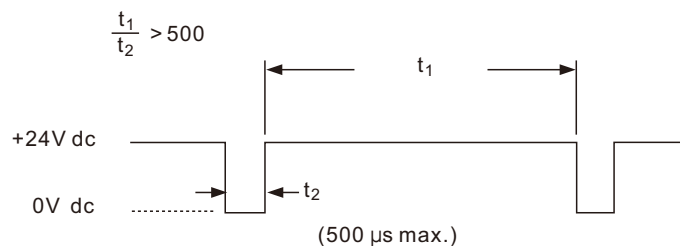

(Pulse output signal requirements for fore-stage safety devices)

> Mechanical installation

SCDA-125R is not a bare connection design. It must be installed inside the box with protection level IP54 or above.

SCDA-125R is directly installed on the 35mm DIN standard track.

> Precautions for heat dissipation

For reliable operation, please make sure that it does not exceed the operating specifications. The shell must provide enough heat dissipation so that the air around the interface module does not exceed the maximum operating temperature specified in the specification. Ways to reduce heat accumulation include ventilation, forced airflow (for example, exhaust fans), sufficient shell surfaces, and spacing between modules and other heat sources.

> Electrical installation

 Warning		<p>Prevent electric shock</p> <ul style="list-style-type: none"> ◆ Please be extra careful to avoid electric shock, which may lead to serious injury or death. ◆ Before performing any or replacing components, be sure to disconnect the power supply of the security system (such as equipment, modules, interfaces, etc.), receiving and protecting devices and/or controlled machines, and using programs such as locking/listing. ◆ The connection to the device or system shall not exceed the instructions in this manual. Electrical installation and wiring must be carried out by qualified personnel and must comply with applicable electrical standards and wiring specifications, such as IEC60204-1, as well as all applicable local standards and specifications.
---	--	---

 Warning		<p>Determine the safety category</p> <ul style="list-style-type: none"> ◆ The design and installation of safety equipment and the interface of these equipment may greatly affect the integrity of the safety circuit. ◆ Perform a risk assessment to determine the appropriate safety circuit integrity level and safety category, as described in ISO 13849-1, to ensure that the expected risk is reduced to meet all applicable regulations and standards. ◆ It is impossible to provide accurate wiring instructions for the security module of the interface, and it is impossible to provide accurate wiring instructions for the security module with the multi-medium machine control configuration interface. The following guiding principles are general principles.
---	--	--

The SCDA-125R safety module has no delay function, and its output relay contacts are opened within 20ms after the safety input is turned on. This will stop the "Category 0" control by the function defined by the security module IEC/EN60204-1.

Input can be connected (meet the requirements of the following pre-level security settings):

1. +24VDC solid state (PNP) output in single-channel or dual-channel wiring configuration
2. Or +24V/0V DC power supply (switched by relay contacts in single-channel or dual-channel wiring configuration)

The dual-channel wiring configuration can detect certain failures and faults of front-level safety equipment, which may lead to the loss of safety functions, such as short circuit. When the insecurity of the control line fails or the fault cannot be eliminated, the dual-channel control mode connection should be adopted.

The circuit shown below can meet the requirements of ISO 13849-1 category 2, 3 or 4, depending on the safety level and the installation of the front-level safety equipment.

The outputs of the front-level safety equipment must at least meet the stated requirements, and these outputs must be monitored by the front-level safety equipment for failure. In addition, if a single output failure cannot produce a normal stop action, the next contact operation cannot be started until the fault is corrected.

Description of typical application wiring diagram

SCDA125R single channel emergency stop, automatic reset, with output monitoring

Automatic reset

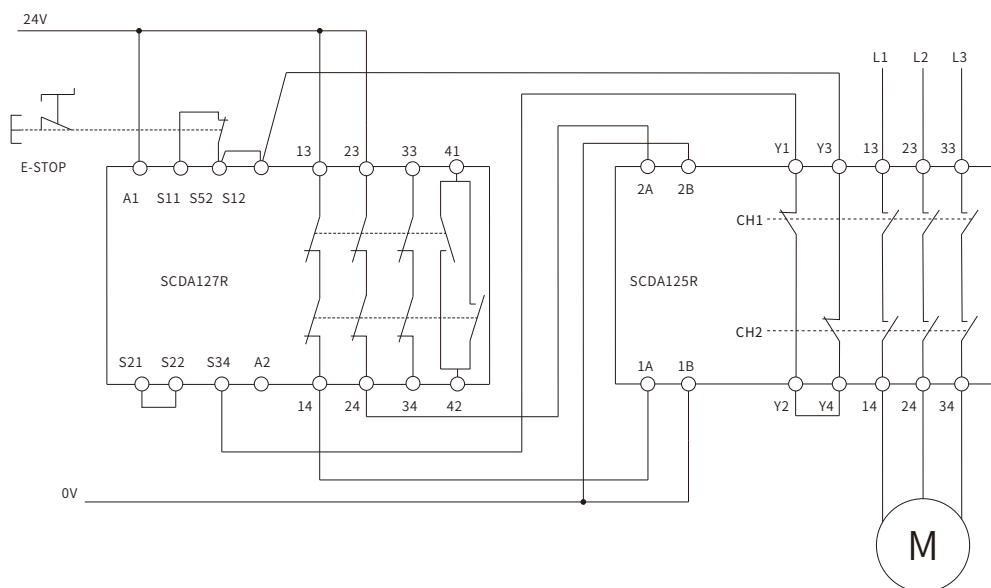

SCDA125R connected to dual channel emergency stop, automatic reset, with output monitoring

Automatic reset

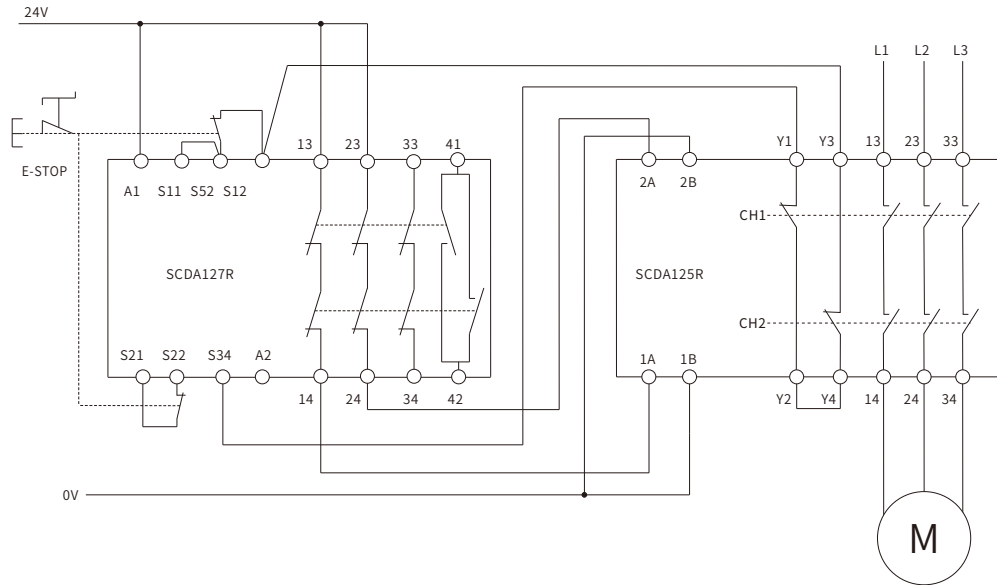

SCDA125R connected to SLC-AD series grating, monitored automatic reset, output monitoring

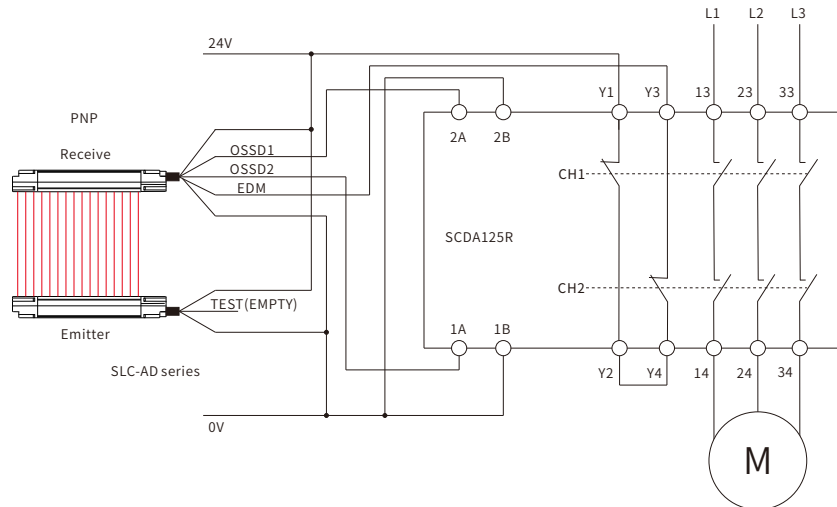

Installation method

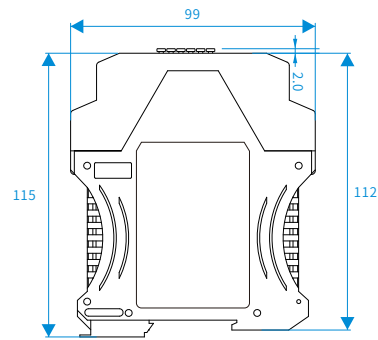
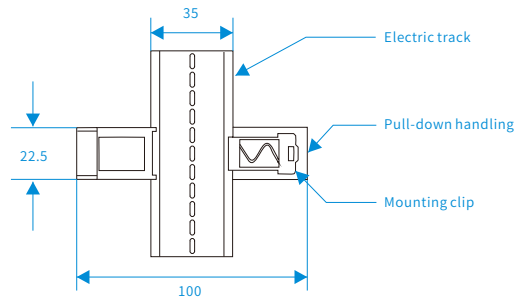

Function description: The safety relay module should be installed in the electronic control box with a protection type of IP54 or above, installed with a DIN rail (35mm) and fixed in the electronic control box.

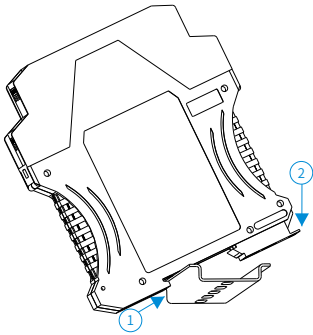

1. The fixed plastic card position of the SCDA series safety module is diagonally stuck to the side of the installation rail;
2. Put down the guide rail and press the SCDA series safety module, so that its hardware movable buckle is clasped to the other side of the guide rail.

	
Warning	<ul style="list-style-type: none"> ◆ Constantly closed output cannot be used as safe output. ◆ Please confirm the wiring when the power is turned off. ◆ Please confirm that the change of power supply voltage does not exceed the rated range. ◆ The power supply must have the function of output overvoltage and overcurrent protection. ◆ Not used in flammable and explosive environments.